

# Product Catalogue



January 2015





# EMERGENCY LOCATION TRANSMITTERS



# What do you require ?

...for an Automatic Fixed or Automatic Portable ELT system

- ① ELT transmitter
- ② Mounting Bracket
- ③ Remote Control Panel
- ④ External Antenna
- ⑤ Connector (minimum) or Programming Dongle (option)
- ⑥ ELT-GPS NAV interface module (option) or Dongle IF GPS Interface (option)

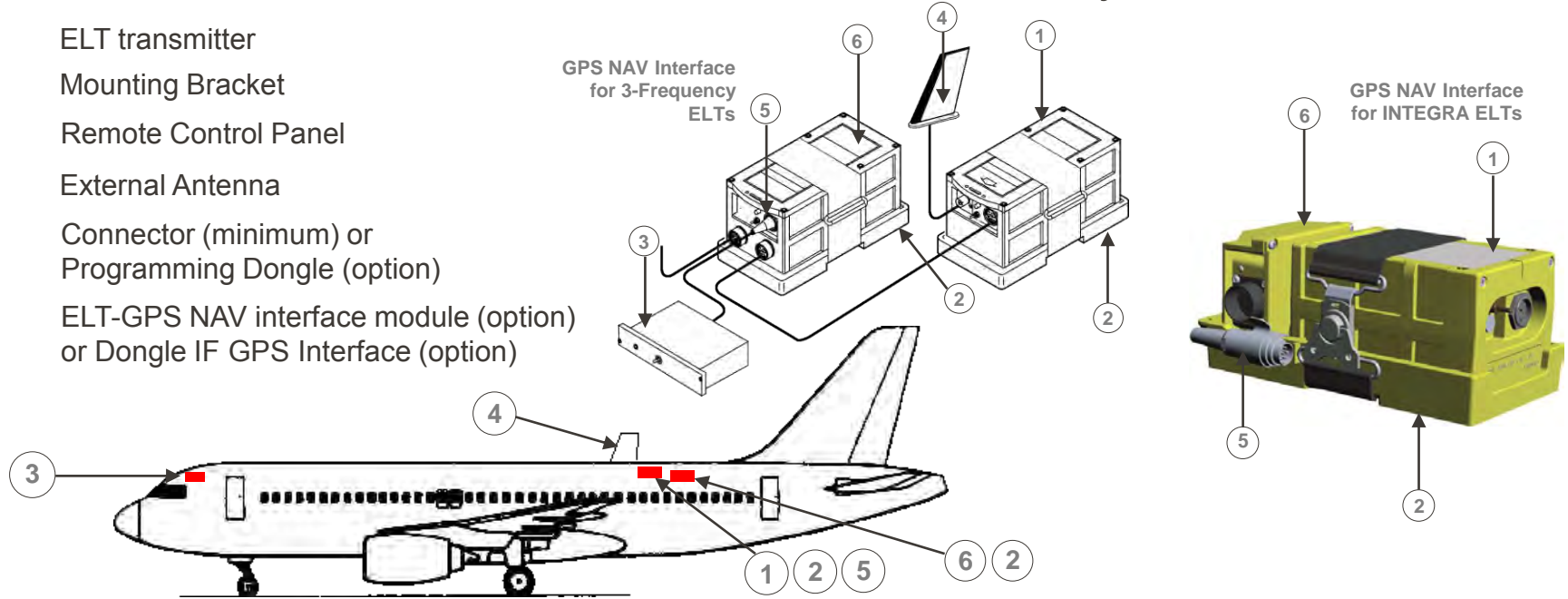

# Exceptions

---

- The external antenna should be installed near the tail except for non metallic aircraft (wood, composite...) where an “auxiliary antenna” connected to the ELT might be accepted by the authorities
- The Remote Control Panel (RCP) is mandatory unless the ELT is “readily accessible from the pilot's normal seated position
- The “Programming dongle” is mandatory for “CS144 interface module” installation;
- The “Programming dongle” is not connected for “ARINC e-NAV” installation (may be attached to the ELT)
- Or the “Programming dongle” is part of the Dongle IF GPS RS232 interface (also named INTEGRA e-NAV NMEA)

# ... for a Survival ELT system

- ① ELT transmitter with auxiliary antenna
- ② Mounting Bracket with “locking pin” (option)
- ③ or Carry-off bag (option)
- ④ Water Switch Sensor (option)
- ⑤ Programming Dongle (option)

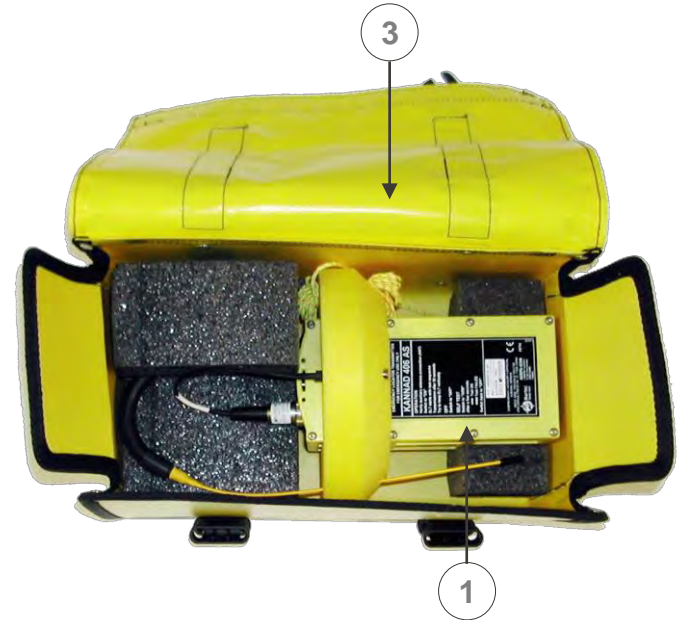
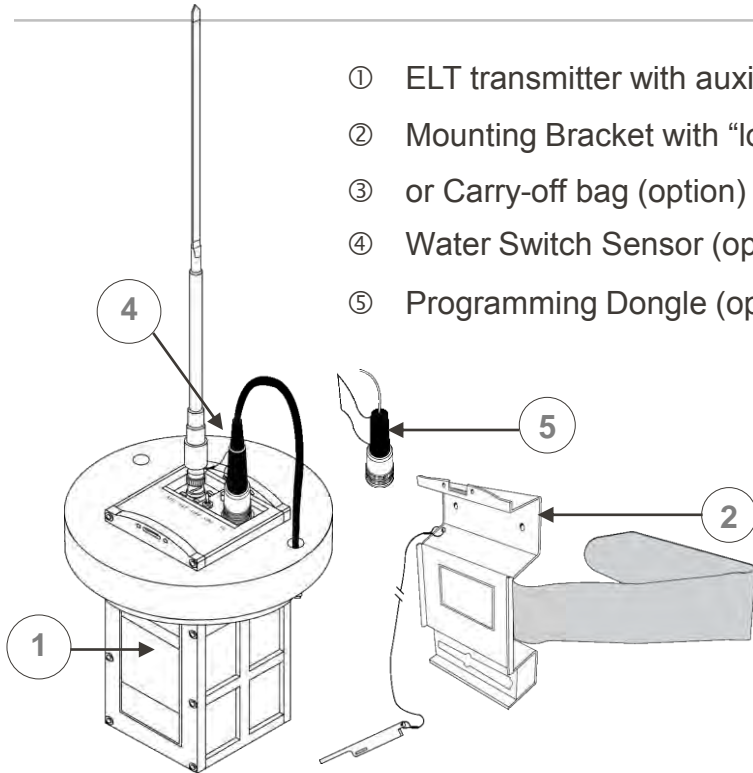



# ELT solutions for all aircraft types

- Commercial aviation
- General Aviation
- Helicopters
- Light Aircraft
- Ultra Light Aircraft



# Typical configurations

---

## “I fly a C172”

- KANNAD 406 AF-Compact Kit + AV200

## Turboprop

- AF or AP INTEGRA+ MB + RC200 + OUTSIDE BUZZER + AV300 Antenna + DONGLE or DONGLE IF GPS RS232 (Option, GARMIN GPS compatible)

## Corporate jet

- AF INTEGRA (ER, or optional ER-N) + MB + RC200 + OUTSIDE BUZZER + ANT650 + DONGLE + optional ARINC e-NAV GPS Interface (ARIN429 or ARINC743 compatible)

## Airliners

- Fixed ELT:  
AF INTEGRA (ER, or optional ER-N)+ MB + RC800 + OUTSIDE BUZZER + ANT650 + DONGLE + optional ARINC e-NAV GPS Interface (ARIN429 or ARINC743 compatible)  
Survival ELT:  
KANNAD 406 Survival or KANNAD 406 TNC + Mounting Bracket AS or Carry-Off Bag

## Helicopter

- AF-H or AP-H INTEGRA + MB + RC200 + AV300 Antenna + DONGLE + optional ARINC e-NAV GPS Interface (ARIN429 or ARINC743 compatible) + OUTSIDE BUZZER (option)

**For more details on how to build a chipset refer to the appropriate presentation  
for Fixed Wing or for Helicopter application**

# ELT transmitters (ELT)

## 406 MHz/121.5 MHz with integral antenna and internal GPS

- AP INTEGRA (ER) P/N S1850501-01
- AP INTEGRA P/N S1850501-02
- AP INTEGRA ER-N PN S1850501-03
- AF INTEGRA (ER) P/N S1851501-01
- AF INTEGRA P/N S1851501-02
- AF INTEGRA ER-N PN S1852501-03
- AF-H INTEGRA (ER) P/N S1852501-01
- AF-H INTEGRA P/N S1852501-02
- AF-H INTEGRA ER-N P/N S1852501-03
- AP-H INTEGRA (ER) P/N S1854501-01
- AP-H INTEGRA ER-N P/N S1854501-03

## 3-Frequency transmitters (121.5 / 243.0 / 406 MHz)

- KANNAD 406 AP P/N S1820502-02
- KANNAD 406 AP-H P/N S1820502-04
- KANNAD 406 AF P/N S1821502-02
- KANNAD 406 AF-H P/N S1822502-02
- KANNAD 406 AF(6D) P/N S1821502-06
- KANNAD 406 AS (TNC) P/N S1823502-03
- KANNAD 406 SURVIVAL P/N S1823502-05

## 406/121.5 MHz for General Aviation

- KANNAD 406 AF-COMPACT P/N S1840501-01

# Common Features & Competitive edges

---

## Major OEM Recognition

### Reliability

- 25 years experience in 406 MHz technology (maritime)
- 15 years experience with more than 22 000 ELTs in service.

### Technical

- Weight & Size (the smallest 406 MHz ELT in the world)
- Complying with latest regulation (JAR-OPS, ICAO...)
- Qualification (ETSO & TSO) on the same P/N (no retrofit required when changing country of registration)
- GPS Nav Interface available for each automatic ELT (exc AF-COMPACT).
- Short circuit protection (no combination of short circuits from the Remote Control Panel wires will stop the ELT once activated)
- Easy programming (no hardware operation)
- Pin-programming option (using a “programming dongle” or “smart connector”)
- 6 year battery

### Customer support and customer care

- Worldwide distribution network
- Worldwide Service Centers network
- Worldwide Repair and Warranty Centers

# INTEGRA ELTs Family with Integral antenna and Internal GPS



# Major improvement

INTEGRA ELTs are an extension of the range of KANNAD 406 ELTs. The development of this type of ELTs is based on the improvement of safety of flights either for light aircraft, business aircraft or commercial aviation.

The INTEGRA ELTs family is composed of AP types (Automatic Portable) and AF types (Automatic Fixed).

Both versions must be connected to an External Antenna, the AP version can be removed from the aircraft and used as Portable (or Survival) ELT when used outside and connected to an Auxiliary Antenna.

The safety of flights of INTEGRA ELTs is strengthened thanks to a built-in GPS giving a more accurate position transmitted within minutes following the distress and an Integral Antenna which may replace the external antenna in case on unavailability of this last one.

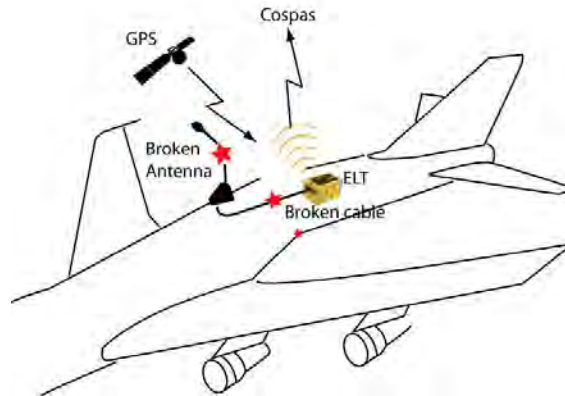

**Note:** The integral antenna has not been tested and approved by Cospas-Sarsat.

# Ways of transmissions

In the event the External Antenna is unavailable due to the crash, the Integral Antenna will replace it to transmit the 406 MHz signal to the Cospas-Sarsat satellites. On AP / AP-H types, survivors can remove the ELT from the aircraft and use it as portable ELT thanks to an Auxiliary Antenna.

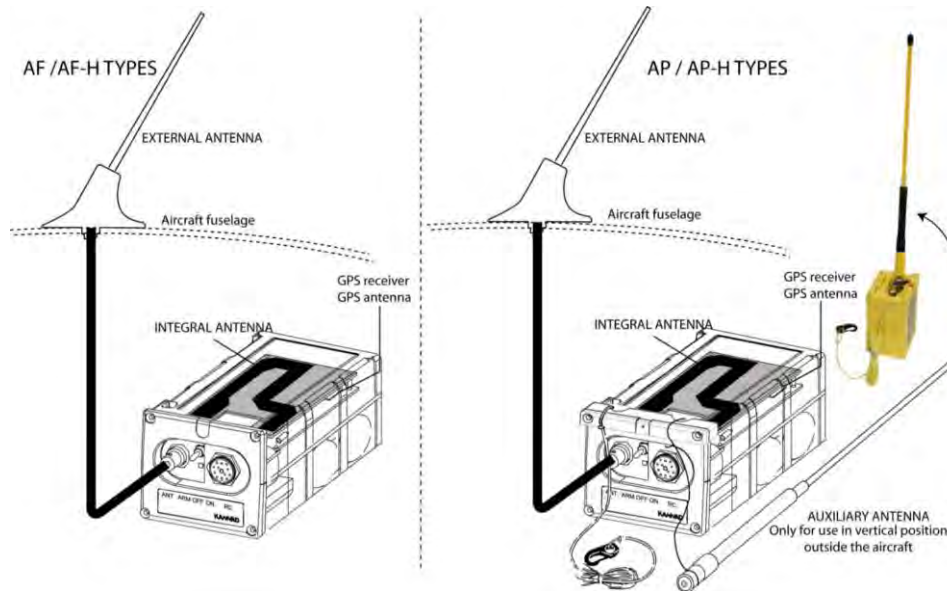

# INTEGRA ELTs Family



# AP INTEGRA (ER) (P/N S1850501-01)

Automatic portable ELT intended to be rigidly attached to the aircraft before the crash and connected to an external antenna but readily removable from the aircraft after a crash to be used as survival ELT (PLB).

## Main features

- Automatic Portable ELT: Type ELT(AP)
- Cospas-Sarsat Class I
- Operating Temperatures -40° to +55°C
- Two-frequency transmitter (121.5 / 406MHz)  
406.037 MHz ,Operating Life time 24 hours at -40°C  
121.5 Homing device, Operating Life time > 48 hours at -40°C
- 6 year battery life-time
- Short Circuit protection
- Internal GPS receiver / Internal GPS antenna
- Integral antenna
- Auxiliary antenna
- Weight: 878 g. (max)
- Transmitter Dimensions: 131x 86 x 75.4 mm
- Overall Dimensions: 285 x 119x 86.4 mm

## Applications

- Fixed wing aircraft
- Can also suit helicopters, but with a special mounting tray (45° nose down)

## Caution

- The "Mounting Bracket" must be ordered separately



Also available with  
**Mounting Bracket TSO-C126b**



**Authorized configurations**

# AF INTEGRA (ER) (P/N S1851501-01)

Automatic Fixed ELT intended to be permanently attached to the aircraft and connected to an external antenna.

## Main features

- Automatic Fixed ELT: Type ELT(AF)
- Cospas-Sarsat Class I
- Operating Temperatures -40° to +55°C
- Two-frequency transmitter (121.5 / 406MHz)  
406.037 MHz ; Operating Life time 24 hours at -40°C  
121.5 Homing device, Operating Life time > 48 hours at -40°C
- 6 year battery life-time
- Short Circuit protection
- Internal GPS receiver / Internal GPS antenna
- Integral antenna transmitter
- Weight: 755 g. (max)
- Transmitter Dimensions: 131x 86 x 75.4 mm
- Overall Dimensions:  
With Mounting Bracket AF Compact : 140 x 98x 86.4 mm  
With Compact Universal Mounting Bracket: 175.12 x 99 .12 x 86.4 mm

## Applications

- Fixed wing aircraft
- Can also suit helicopters, but with a special mounting tray (45° nose down)

## Caution

- The "Mounting Bracket" must be ordered separately



Also available with  
Mounting Bracket TSO-C126b

Authorized configurations

# AF-H INTEGRA (ER) (P/N S1852501-01)

Automatic Fixed ELT intended to be permanently attached to the aircraft and connected to an external antenna.

## Main features

- Automatic Fixed ELT: Type ELT(AF)
- Cospas-Sarsat Class I
- Operating Temperatures -40° to +55°C
- Two-frequency transmitter (121.5 / 406MHz)  
406.037 MHz ,Operating Life time 24 hours at -40°C  
121.5 Homing device, Operating Life time > 48 hours at -40°C
- 6 year battery life-time
- Short Circuit protection
- Internal GPS receiver / Internal GPS antenna
- Integral antenna transmitter
- Weight: 760g. (max)
- Transmitter Dimensions: 131x 86 x 75.4 mm
- Overall Dimensions:  
With Mounting Bracket AF Compact : 140 x 98x 86.4 mm  
With Compact Universal Mounting Bracket: 175.12 x 99 .12 x 86.4 mm

## Applications

- Flat (or vertical) installation on board helicopters only

## Caution

- The "Mounting Bracket" must be ordered separately

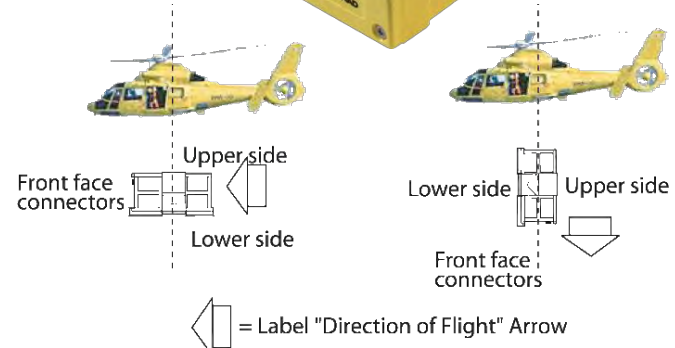

Also available with  
Mounting Bracket TSO-C126b

# AP-H INTEGRA (ER) (P/N S1854501-01)

Automatic portable ELT intended to be rigidly attached to the aircraft before the crash and connected to an external antenna but readily removable from the aircraft after a crash to be used as survival ELT (PLB).

## Applications

- Automatic Portable ELT: Type ELT(AP)
- Cospas-Sarsat Class I  
Operating Temperatures -40° to +55°C
- Two-frequency transmitter (121.5 / 406MHz)  
406.037 MHz ,Operating Life time 24 hours at -40°C  
121.5 Homing device, Operating Life time > 48 hours at -40°C
- 6 year battery life-time
- Short Circuit protection
- Internal GPS receiver / Internal GPS antenna
- Integral antenna transmitter
- Auxiliary antenna
- Weight: 883 g. (max)
- Transmitter Dimensions: 131x 86 x 75.4 mm
- Overall Dimensions: 285 x 119x 86.4 mm

## Applications

- Flat (or vertical) installation on board helicopters only

## Caution

- The "Mounting Bracket" must be ordered separately



Also available with  
Mounting Bracket TSO-C126b



Vertical position when used outside



Authorized configurations

# AP INTEGRA (P/N S1850501-02)

Automatic portable ELT intended to be rigidly attached to the aircraft before the crash and connected to an external antenna but readily removable from the aircraft after a crash to be used as survival ELT (PLB).

## Applications

- Automatic Portable ELT: Type ELT(AP)
- Cospas-Sarsat Class II:
- Operating Temperatures -20° to +55°C
- Two-frequency transmitter (121.5 / 406MHz):  
406.037 MHz ,Operating Life time 24 hours at -20°C  
121.5 Homing device, Operating Life time > 48 hours at -20°C
- 6 year battery life-time
- Short Circuit protection
- Internal GPS receiver / Internal GPS antenna
- Integral antenna transmitter
- Auxiliary antenna
- Weight: 878 g. (max)
- Transmitter Dimensions: 131x 86 x 75.4 mm
- Overall Dimensions: 285 x 119x 86.4 mm

## Applications

- Fixed wing aircraft
- Can also suit helicopters, but with a special mounting tray (45° nose down)

## Caution

- The "Mounting Bracket" must be ordered separately



Also available with  
**Mounting Bracket TSO-C126b**



**Authorized configurations**

# AF INTEGRA (P/N S1851501-02)

Automatic Fixed ELT intended to be permanently attached to the aircraft and connected to an external antenna.

## Applications

- Automatic Fixed ELT: Type ELT(AF)
- Cospas-Sarsat Class II:  
Operating Temperatures -20° to +55°C
- Two-frequency transmitter (121.5 / 406MHz):  
406.037 MHz ,Operating Life time 24 hours at -20°C  
121.5 Homing device, Operating Life time > 48 hours at -20°C
- 6 year battery life-time
- Short Circuit protection
- Internal GPS receiver / Internal GPS antenna
- Integral antenna transmitter
- Weight: 755 g. (max)
- Transmitter Dimensions: 131x 86 x 75.4 mm
- Overall Dimensions:  
With Mounting Bracket AF Compact : 140 x 98x 86.4 mm  
With Compact Universal Mounting Bracket; 175.12 x 99 .12 x 86.4 mm



## Applications

- Fixed wing aircraft
- Can also suit helicopters, but with a special mounting tray (45° nose down)

## Caution

- The "Mounting Bracket" must be ordered separately

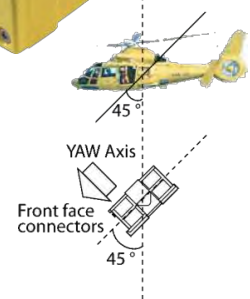
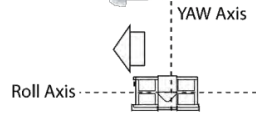

◀ = Label "Direction of Flight" Arrow

**Also available with  
Mounting Bracket TSO-C126b**

**Authorized configurations**

# AF-H INTEGRA (P/N S1852501-02)

Automatic Fixed ELT intended to be permanently attached to the aircraft and connected to an external antenna.

## Applications

- Automatic Fixed ELT: Type ELT(AF)
- Cospas-Sarsat Class II:  
Operating Temperatures -20° to +55°C
- Two-frequency transmitter (121.5 / 406MHz):  
406.037 MHz ,Operating Life time 24 hours at -20°C  
121.5 Homing device, Operating Life time > 48 hours at -20°C
- 6 year battery life-time
- Short Circuit protection
- Internal GPS receiver / Internal GPS antenna
- Integral antenna transmitter
- Weight: 760g. (max)
- Transmitter Dimensions: 131x 86 x 75.4 mm
- Overall Dimensions:  
With Mounting Bracket AF Compact : 140 x 98x 86.4 mm  
With Compact Universal Mounting Bracket: 175.12 x 99 .12 x 86.4 mm

## Applications

- Flat (or vertical) installation on board helicopters only

## Caution

- The "Mounting Bracket" must be ordered separately



Supplied with auxiliary antenna

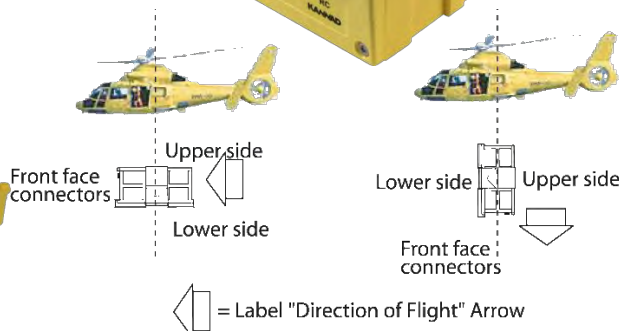

Also available with  
Mounting Bracket TSO-C126b

Authorized configurations

# AP INTEGRA (ER-N) (P/N S1850501-03)

Automatic portable ELT intended to be rigidly attached to the aircraft before the crash and connected to an external antenna but readily removable from the aircraft after a crash to be used as survival ELT (PLB).

## Applications

- Automatic Portable ELT: Type ELT(AP)
- Cospas-Sarsat Class I
- Operating Temperatures -40° to +55°C
- Two-frequency transmitter (121.5 / 406MHz)  
406.037 MHz ,Operating Life time 24 hours at -40°C  
121.5 Homing device, Operating Life time > 48 hours at -40°C
- 6 year battery life-time
- Short Circuit protection
- Internal GPS receiver / Internal GPS antenna
- Integral antenna
- Auxiliary antenna
- Weight: 878 g. (max)
- Transmitter Dimensions: 131x 86 x 75.4 mm
- Overall Dimensions: 285 x 119x 86.4 mm

## Applications

- Fixed wing aircraft
- Can also suit helicopters, but with a special mounting tray (45° nose down)

## Caution

- **Compatible with INTEGRA ARINC e-NAV P/N S1850581-01 ELT shall always be connect to INTEGRA ARINC e-NAV**
- The "Mounting Bracket" must be ordered separately

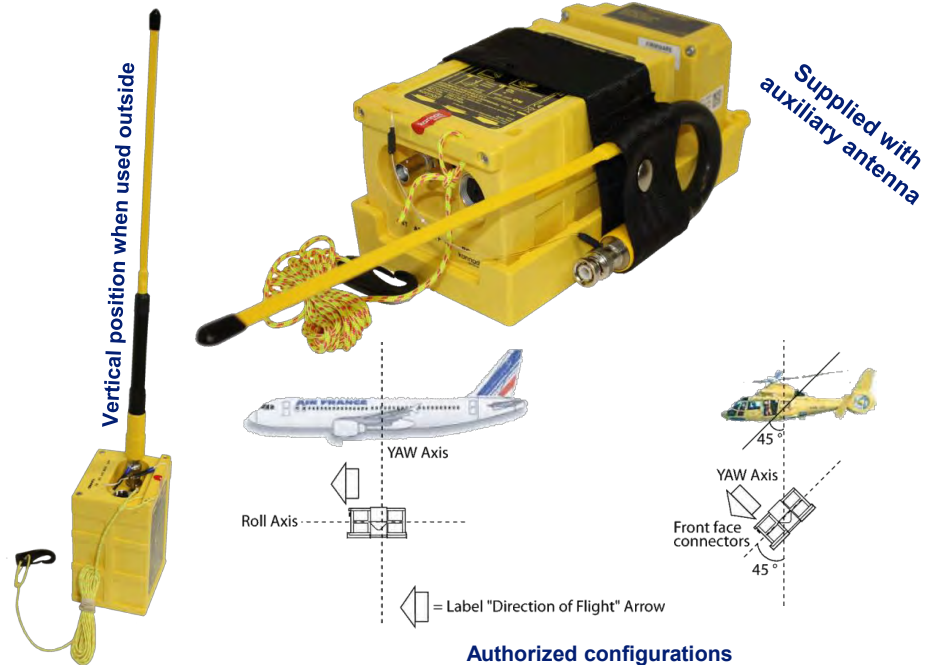



# AF INTEGRA (ER-N) (P/N S1851501-03)

Automatic Fixed ELT intended to be permanently attached to the aircraft and connected to an external antenna.

## Applications

- Automatic Fixed ELT: Type ELT(AF)
- Cospas-Sarsat Class I
- Operating Temperatures -40° to +55°C
- Two-frequency transmitter (121.5 / 406MHz)  
406.037 MHz, Operating Life time 24 hours at -40°C  
121.5 Homing device, Operating Life time > 48 hours at -40°C
- 6 year battery life-time
- Short Circuit protection
- Internal GPS receiver / Internal GPS antenna
- Integral antenna transmitter
- Weight: 755 g. (max)
- Transmitter Dimensions: 131x 86 x 75.4 mm
- Overall Dimensions:  
With Bracket Universal for ARINC e-NAV for ELT (AF): Max 205 mm x 119 mm x 87 mm



## Applications

- Fixed wing aircraft
- Can also suit helicopters, but with a special mounting tray (45° nose down)

## Caution

- **Compatible with INTEGRA ARINC e-NAV P/N S1850581-01**  
**ELT shall always be connect to INTEGRA ARINC e-NAV**
- The "Mounting Bracket" must be ordered separately

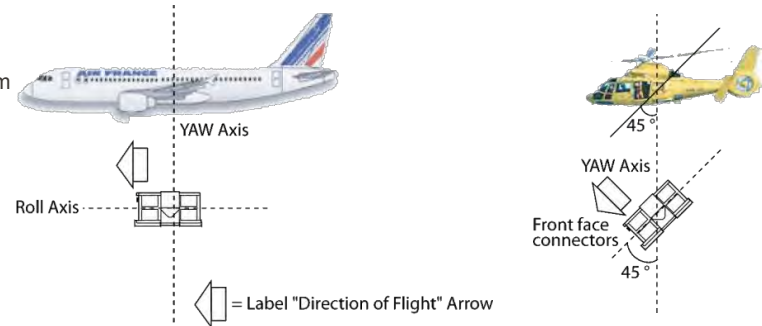

Authorized configurations

# AF-H INTEGRA (ER-N) (P/N S1852501-03)

Automatic Fixed ELT intended to be permanently attached to the aircraft and connected to an external antenna.

## Applications

- Automatic Fixed ELT: Type ELT(AF)
- Cospas-Sarsat Class I
- Operating Temperatures -40° to +55°C
- Two-frequency transmitter (121.5 / 406MHz)  
406.037 MHz ,Operating Life time 24 hours at -40°C  
121.5 Homing device, Operating Life time > 48 hours at -40°C
- 6 year battery life-time
- Short Circuit protection
- Internal GPS receiver / Internal GPS antenna
- Integral antenna transmitter
- Weight: 760g. (max)
- Transmitter Dimensions: 131x 86 x 75.4 mm
- Overall Dimensions:  
With Bracket Universal for ARINC e-NAV for ELT (AF): Max 205 mm x 119 mm x 87 mm

## Applications

- Flat (or vertical) installation on board helicopters only

## Caution

- **Compatible with INTEGRA ARINC e-NAV P/N S1850581-01**  
**ELT shall always be connect to INTEGRA ARINC e-NAV**
- **The “Mounting Bracket” must be ordered separately**

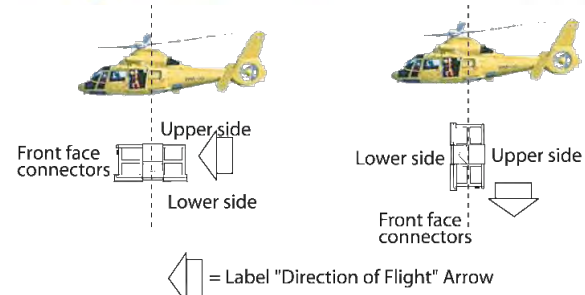

**Authorized configurations**

# AP-H INTEGRA (ER-N) (P/N S1854501-03)

Automatic portable ELT intended to be rigidly attached to the aircraft before the crash and connected to an external antenna but readily removable from the aircraft after a crash to be used as survival ELT (PLB).

## Applications

- Automatic Portable ELT: Type ELT(AP)
- Cospas-Sarsat Class I
- Operating Temperatures -40° to +55°C
- Two-frequency transmitter (121.5 / 406MHz)  
406.037 MHz ,Operating Life time 24 hours at -40°C  
121.5 Homing device, Operating Life time > 48 hours at -40°C
- 6 year battery life-time
- Short Circuit protection
- Internal GPS receiver / Internal GPS antenna
- Integral antenna transmitter
- Auxiliary antenna
- Weight: 883 g. (max)
- Transmitter Dimensions: 131x 86 x 75.4 mm
- Overall Dimensions:  
Antenna folded with Bracket Universal for ELT (AP):  
Max 360 mm x 149 mm x 88 mm

## Applications

- Flat (or vertical) installation on board helicopters only

## Caution

- **Compatible with INTEGRA ARINC e-NAV P/N S1850581-01**  
**ELT shall always be connect to INTEGRA ARINC e-NAV**
- The "Mounting Bracket" must be ordered separately

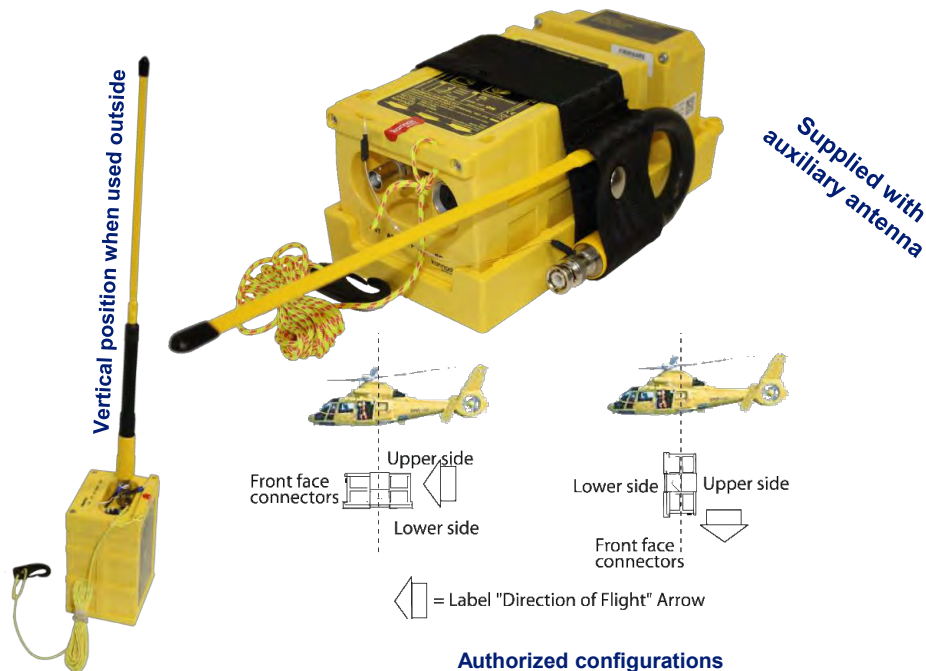

# Packs INTEGRA AF (P/N 1202502) / INTEGRA AF-H (P/N 1202503)



Offered as a complete pack including transmitter, mounting bracket, RCP and connectors, the INTEGRA AF Pack or INTEGRA AF-H Packs consists of:

1. Transmitter AF INTEGRA designed for flat installation on fix wings aircraft or specific installation on helicopters (PACK P/N 1202502); or Transmitter AF-H INTEGRA designed for flat installation on helicopters (Pack P/N 1202503)
2. COMPACT Universal Mounting bracket designed for retrofit to replace a former 121.5 ELT by an AF or AF- H INTEGRA
3. RC200 Remote Control Panel
4. DIN-12 connector
5. SUB-D 9 Pts Female connector

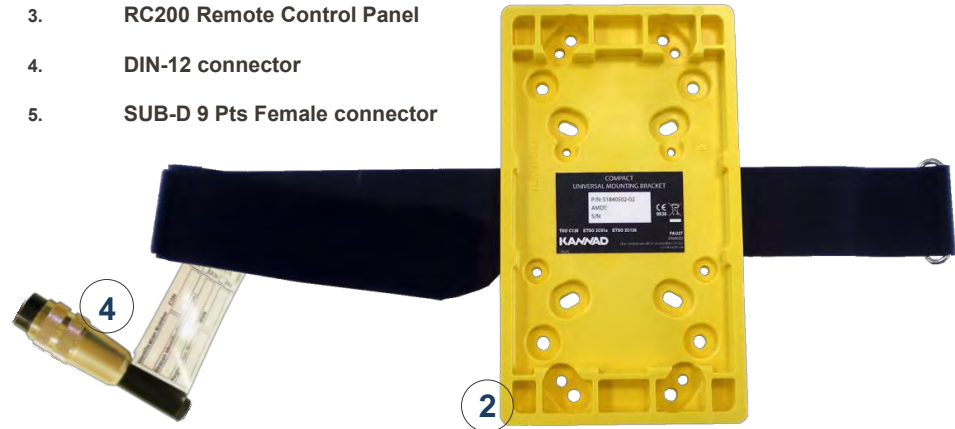

# Kannad Integra Smart Pack with GPS Navigation Interface (P/N 1000337)

## Kannad Integra Smart Pack: INTEGRA ELT + Cable to connect Aircraft GPS + Remote Control Panel + Mounting Bracket

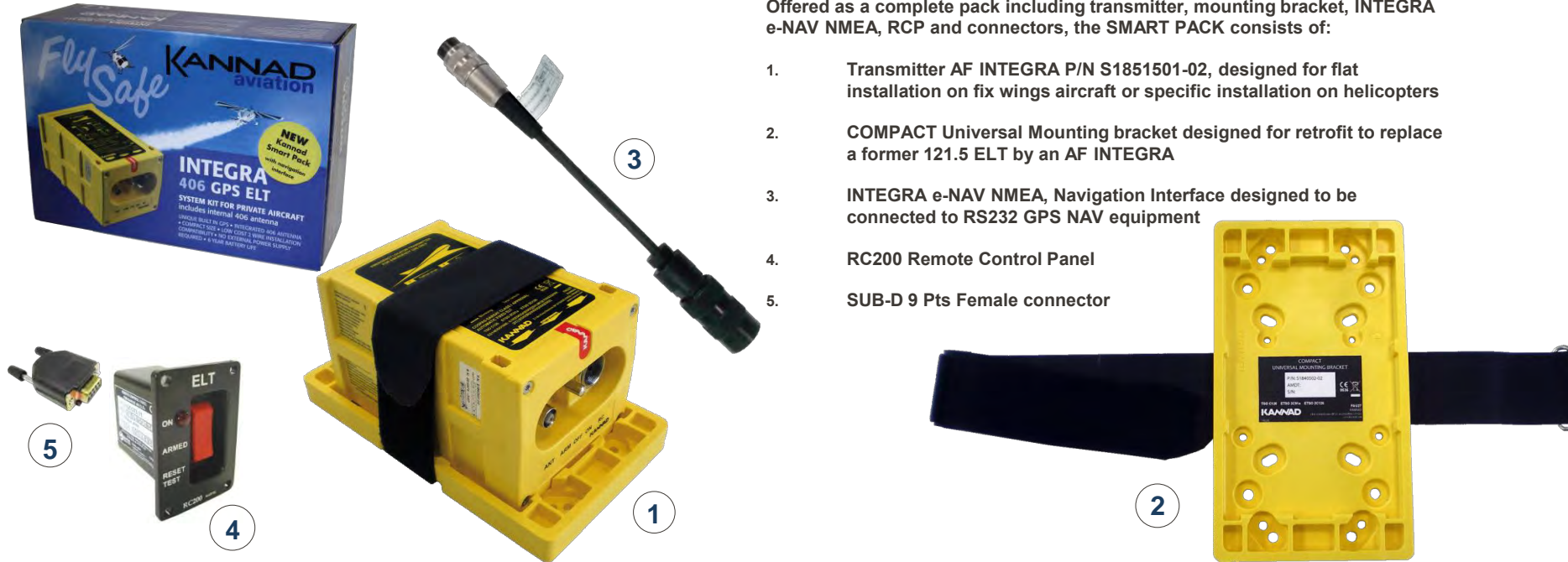

Offered as a complete pack including transmitter, mounting bracket, INTEGRA e-NAV NMEA, RCP and connectors, the SMART PACK consists of:

1. Transmitter AF INTEGRA P/N S1851501-02, designed for flat installation on fix wings aircraft or specific installation on helicopters
2. COMPACT Universal Mounting bracket designed for retrofit to replace a former 121.5 ELT by an AF INTEGRA
3. INTEGRA e-NAV NMEA, Navigation Interface designed to be connected to RS232 GPS NAV equipment
4. RC200 Remote Control Panel
5. SUB-D 9 Pts Female connector



# KANNAD 406 AF-COMPACT (P/N S1840501-01)



## Main features

- Automatic Fixed ELT: Type ELT(AF)
- Cospas-Sarsat Class II (Operating temperature -20°C to +55°C)
- Specifically designed to satisfy the requirements of general aviation
- Two frequency transmitter (121.5 / 406MHz)
- 6 year battery life-time
- Short Circuit protection
- Weight: Typical 850g Max 875g
- Dimensions: 140 x 98 x 86.4mm
- Can easily be held in one hand
- Fixed wing aircraft
- Can also suit helicopters but with a special mounting tray (45° nose down)
- **Now compatible with 2-wire remote control panels**

## Applications

Selected by :

- Robinson Helicopters
- Aquila A/C
- Quest, Lancair
- AOPA New Zealand

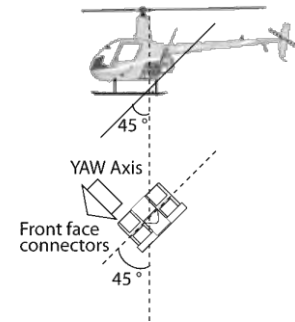
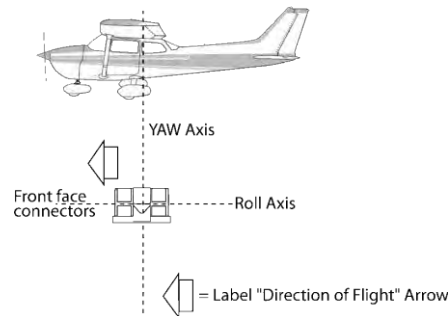

# Pack KANNAD 406 AF-COMPACT (P/N S1840501-02)

Offered as a complete pack including transmitter, mounting bracket, RCP and connectors, the KANNAD 406 AF-COMPACT Pack consists of:

1. Transmitter KANNAD 406 AF-COMPACT
2. COMPACT Universal Mounting bracket designed for retrofit to replace a former 121.5 ELT by a KANNAD 406-AF COMPACT
3. RC200 Remote Control Panel
4. DIN-12 connector
5. SUB-D 9 Pts Female connector





# 3-Frequency ELTs



# KANNAD 406 AP (P/N S1820502-02)

## Main features

- Automatic Portable ELT: Type ELT(AP)
- Three frequency transmitter (121.5 / 243 / 406MHz)
- 6 year battery life-time
- Short Circuit protection
- Weight: 1290g (max)
- Transmitter Dimensions: 172 x 82 x 82mm
- Overall Dimensions: 290 x 115 x 95mm

## Applications

- Fixed wing aircraft
- Can also suit helicopters, but with a special mounting tray (45° nose down)
- Forward fit on
  - CESSNA Citation X, Exel, Sovereign
  - BOMBARDIER Dash8-Q400, BD100 (Continental Jet)
  - PILATUS PC12, PC21
  - EUROCOPTER

## Caution

- The "Mounting Bracket, 1 Strap" must be ordered separately

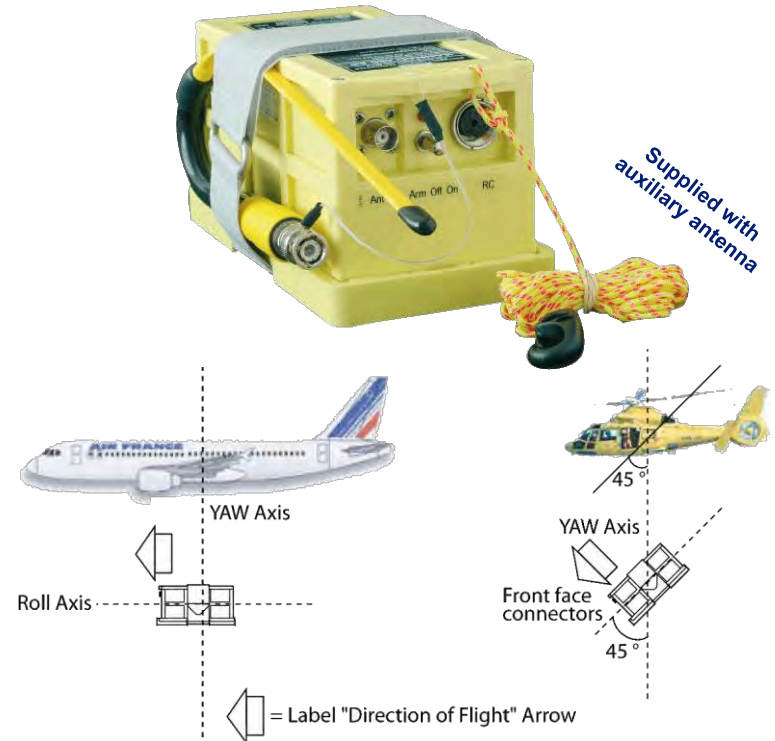

# KANNAD 406 AP-H (P/N S1820502-04)

## Main features

- Automatic Portable ELT: Type ELT(AP)
- Specially designed for helicopters
- Three frequency transmitter (121.5 / 243 / 406MHz)
- 6 year battery life-time
- Short Circuit protection
- Weight: 1290g (max)
- Transmitter Dimensions: 172 x 82 x 82mm
- Overall Dimensions: 290 x 115 x 95mm

## Applications

- Flat (or vertical) installation on board helicopters

## Caution

- The "Mounting Bracket, 1 Strap" must be ordered separately

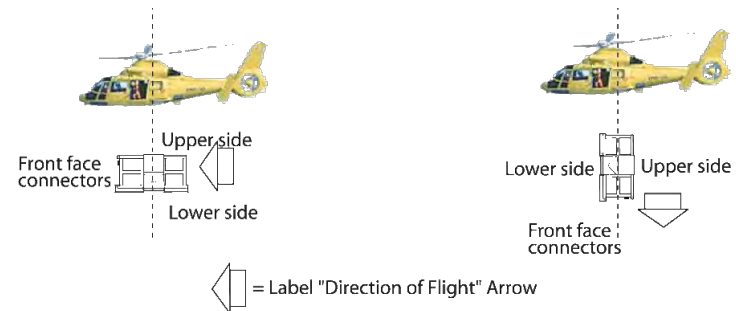

# KANNAD 406 AF (P/N S1821502-02)

## Main features

- Automatic Fixed ELT: Type ELT(AF)
- Three frequency transmitter (121.5 / 243 / 406MHz)
- 6 year battery life-time
- Short Circuit protection
- Weight: 1180g (max)
- Transmitter Dimensions: 172 x 82 x 82mm

## Applications

- Can also suit helicopters but with a special mounting tray (45° nose down)
- Forward fit on
  - CESSNA Citation X, Exel, Sovereign
  - BOMBARDIER Dash8-Q400, BD100 (Continental Jet)
  - PILATUS PC12, PC21
  - EUROCOPTER

## Caution

- The "Mounting Bracket, 1 Strap" must be ordered separately



# KANNAD 406 AF-H (P/N S1822502-02)

## Main features

- Automatic Fixed ELT: Type ELT(AF)
- Specially designed for helicopters
- Three frequency transmitter (121.5 / 243 / 406MHz)
- 6 year battery life-time
- Short Circuit protection
- Weight: 1190g (max)
- Transmitter Dimensions: 172 x 82 x 82mm

## Applications

- Flat (or vertical) installation on board helicopters
- Forward fit on
  - EUROCOPTER EC120, EC130
  - EUROCOPTER TIGER

## Caution

- The "Mounting Bracket, 1 Strap" must be ordered separately

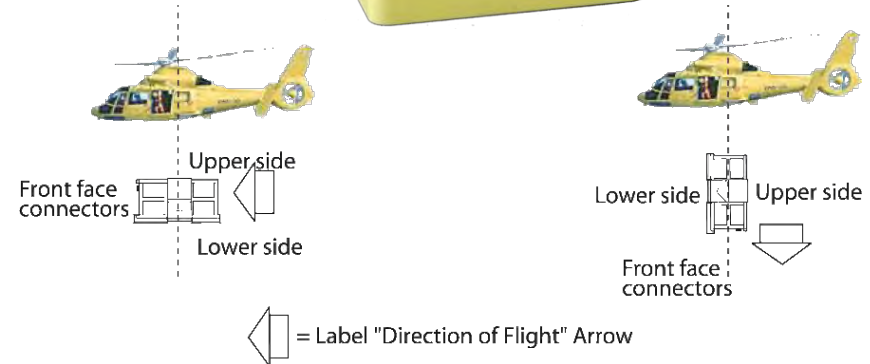

# KANNAD 406 AS TNC (P/N S1823502-03)

## Main features

- Survival ELT: Type ELT(S)
- Three frequency transmitter (121.5 / 243 / 406MHz)
- 6 year battery life-time
- Overall dimensions (antenna deployed) 590 mm x 160 mm x 160 mm
- Overall dimensions (packed) 290 mm x 165 mm x 165 mm
- Overall dimensions (on mounting bracket) 300 mm x 162 mm x 160 mm
- Weight (including battery, auxiliary antenna and flotation collar) typical 1180g / max 1250g

## Applications

- Installation in the cabin or stowed inside the life raft
- Selected by British Airways for the whole fleet and by Australian Airforce
- Can be installed on "Mounting Bracket, AS" or in a "Carry-off bag, AS"
- Can be automatically activated in contact with water if "Water Switch Sensor Kit" (P/N S1820514-14)

## Caution

- Fitted with a TNC antenna receptacle
- Mounting bracket AS or AS-PLUS or Carry-off bag must be ordered separately



# Water Switch Sensor KIT (P/N S1820514-14)

## Kit content

- A water switch sensor connector fitted with:
- A Din-12 connector for connection to the ELT
- An RCA plug used as electrodes
- Four ballasts to counter-balance the weight located on the upper side of the ELT and to improve stability in the water in a vertical position
- A label warning "SWITCH TO ARM TO ENABLE AUTOMATIC ACTIVATION"

## Applications

- To enable activation of ELT when immersed in water
- Connector dimensions 66mm x Ø 17mm
- Water Switch Sensor weight 35g (max. 37g)
- Ballast weight: 20g each (max. 22 g)

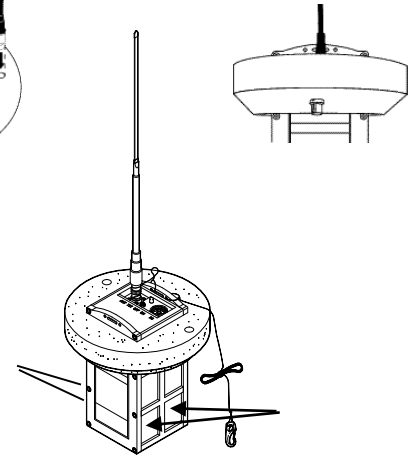
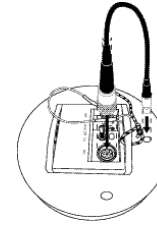
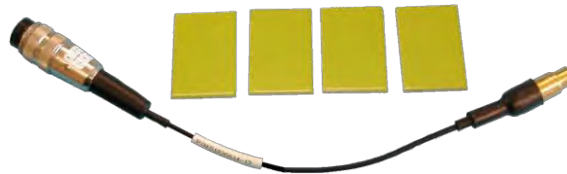

# KANNAD 406 SURVIVAL (P/N S1823502-05)



## Main features

- Three frequency transmitter (121.5 / 243 / 406MHz)
- 6 year battery life-time
- Overall dimensions (antenna deployed) 590mm x 160mm x 160mm
- Overall dimensions (packed) 290mm x 165mm x 165mm
- Overall dimensions (on mounting bracket) 300mm x 162mm x 160mm
- Weight (including battery, auxiliary antenna, flotation collar and water switch sensor) typical 1305g / max 1375g

## Applications

- Installation in the cabin or stowed inside the life raft
- Selected by UNITED AIRLINES
- Can be installed on "Mounting Bracket, AS" or in a "Carry-off bag, AS"
- Automatically activated in contact with water

## Caution

- Fitted with a TNC antenna receptacle
- Mounting bracket AS or AS-PLUS or Carry-off bag must be ordered separately





# ELT / NAV INTERFACES

---

The purpose of the ELT/NAV interface is to receive the on board GPS position and store them until an eventual ELT activation. These data are included in the 406 MHz message being transmitted to COSPAS-SARSAT satellite system to accurately identify the ELT position in the event of ELT activation.

This position will be transmitted after the ELT activation.

**ARINC429** - Compatible with all 3-Frequency KANNAD 406 ELTs except, AS and SURVIVAL

- ELT-NAV INTERFACE KIT, CS144-A P/N S1825501-02

**ARINC429 / ARINC743** - Compatible with ELTs INTEGRA (ER-N) family

- INTEGRA ARINC e-NAV P/N S1850581-01

**RS232** - Compatible with all INTEGRA ELTs except INTEGRA (ER-N)

- DONGLE, RS232 IFGPS P/N S1820514-08

# ELT-NAV Interface Kit, CS144-A (P/N S1825501-02)

## ARINC429 Interface for 3-Frequency KANNAD 406 ELTs

### Main features

- Combines the aircraft identification (contained in the programming dongle) with the aircraft position to generate the appropriate long message
- Every minute, updates an internal memory module that contains either the short or the long message
- Fits between ELT and dongle
- Connected to NAV equipment with ARINC 429 (Low or High speed)
- NAV equipment must send ARINC 429 labels 310 and 311
- Weight: 650g
- Dimensions : 180 x 82 x 82mm

### Applications

- Compatible with all 3-Frequency KANNAD 406 ELTs except, AS and SURVIVAL.
- Compatible with all RCP manufactured by Orolia S.A.S.
- Compatible with all Programming Dongles manufactured by Orolia S.A.S.

### Caution

- ELT-NAV Interface Kit (P/N S1825501-02) includes ELT-NAV interface unit (P/N S1825502-02) plus CS144 to ELT cable (P/N S1825503-01)
- Distance between ELT and CS144 must be less than 45 cm
- The "Mounting Bracket, 1 Strap" (S1820511-01) must be ordered separately
- The use of a programming dongle is mandatory

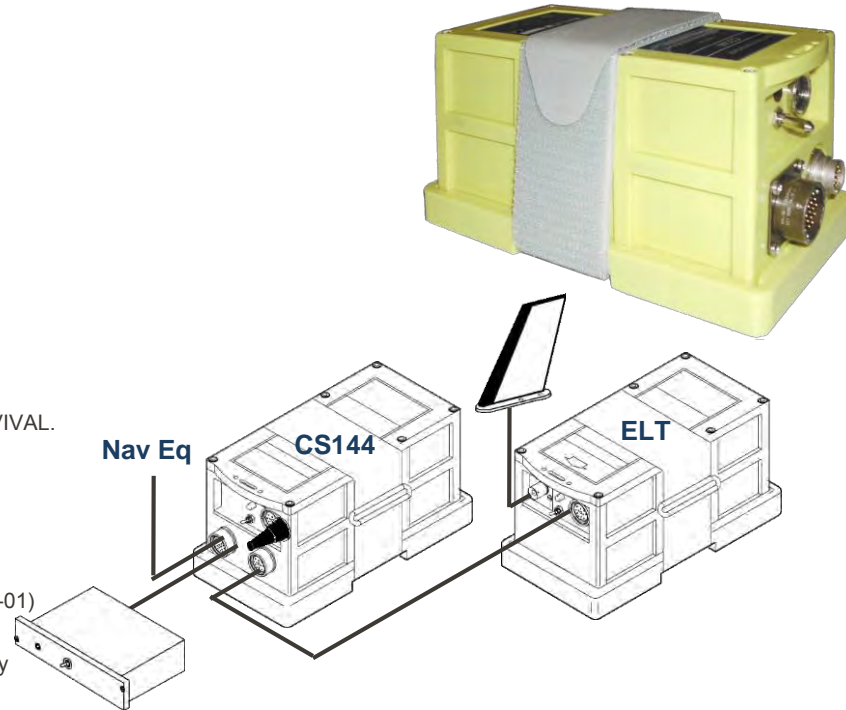

# INTEGRA ARINC e-NAV (P/N S1850581-01)

## ARINC429 / ARINC743 Interface for INTEGRA ELTs ER-N, Installation on Board

- Designed to be installed on a “Bracket Universal for INTEGRA e-NAV ARINC for ELT (AF)” P/N S1850551-02 or a “Bracket Universal for INTEGRA e-NAV ARINC for ELT (AP)” P/N S1850551-01
- The ELT is installed in the same mounting bracket than the INTEGRA ARINC e-NAV
- A programming dongle can be attached to the mounting bracket

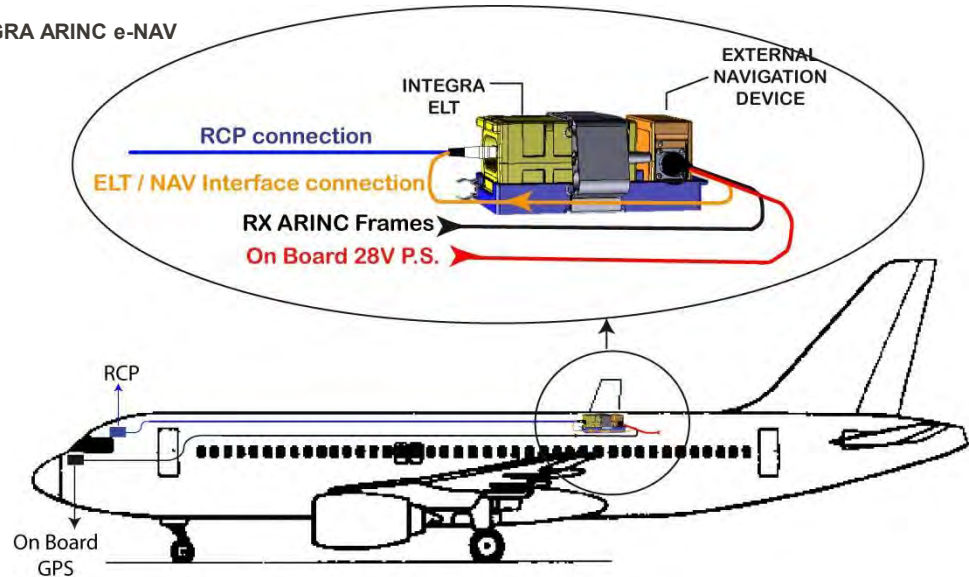

# DONGLE IF GPS RS232 INTEGRA e-NAV NMEA

## RS232 Interface for INTEGRA ELTs

- Dongle IF GPS RS232

P/N S1820514-08

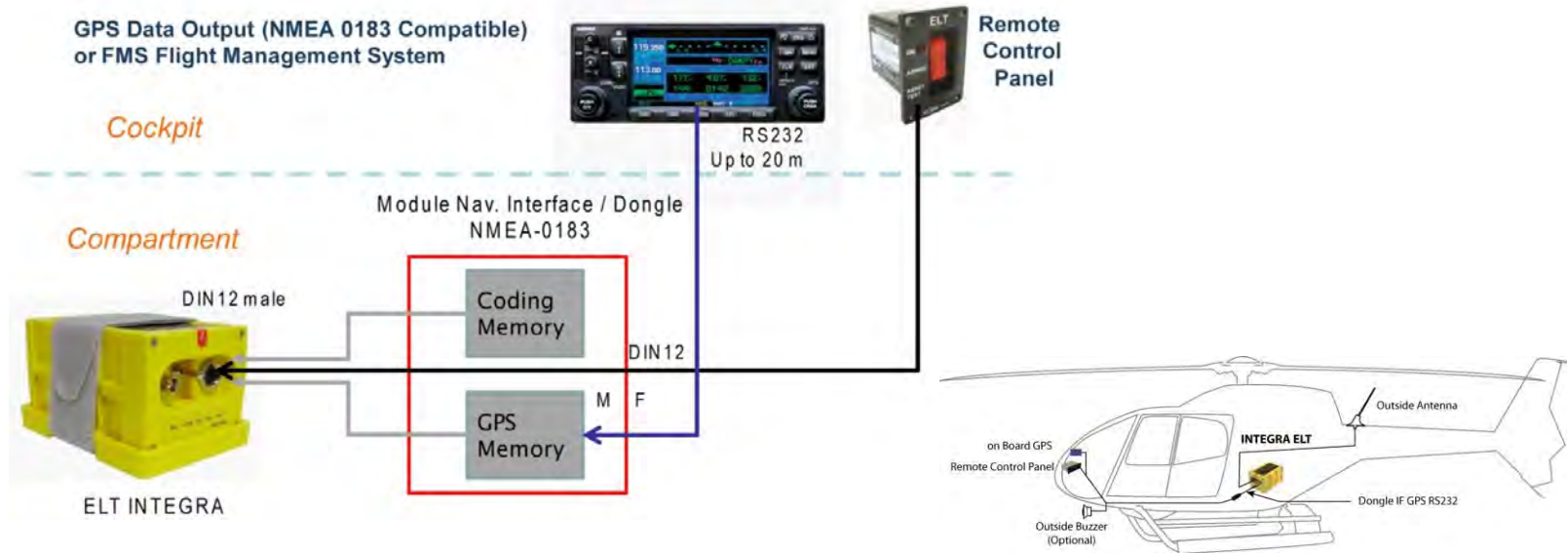

# DONGLE IF-GPS RS232 (P/N S1820514-08)

## INTEGRA e-NAV NMEA

### Main features

- ELT/NAV interface compatible with all INTEGRA ELTs except INTEGRA (ER-N)
- Compliant with Cospas-Sarsat specifications
- Connected to NAV equipment with RS232
- Sentence Format: GPGGA, GPRMC, GPGLL
- Speed up to 9600 bauds
- NAV equipment must send NMEA 0183
- GPS Compatible: GARMIN GNS 430 & 430 WAS
- Fitted with a Programming Dongle
- Weight: 100 g
- Dimensions : Length 350 mm

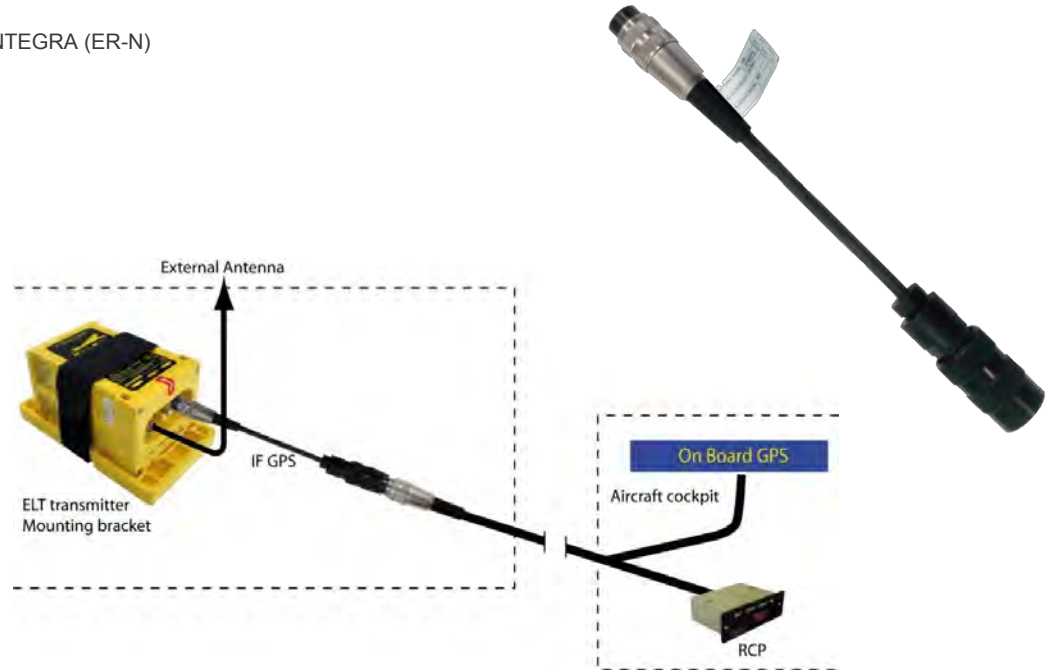

# INTEGRA ARINC e-NAV (P/N S1850581-01)

## ARINC429 / ARINC 743 Interface for INTEGRA ELTs ER-N

### Main features

- External Navigation Device (END) used for INTEGRA ELTS and navigation equipment through ARINC 429/743
- Used to store GPS data coming from an on-board GPS ARINC429/ARINC743 output
- The position data is transmitted in the 406MHz distress message as soon as the ELT is activated
- NAV equipment must send ARINC429 labels 310 and 311 or ARINC743 labels 110 and 110,
- Power supplied by on board 28 VDC power supply
- Operating temperatures: -40°C to + 55°C
- Weight: 176 g (1350 g to 1555 g with ELT and Mounting Bracket according to ELT types)
- Dimensions : 91 mm x 71 mm x 76 mm  
(205 mm x 119 mm x 87 mm with ELT Automatic Fixed and Mounting Bracket)  
(360 mm x 149 mm x 88 mm with ELT Automatic Portable and Mounting Bracket)

### Applications

- Compatible with ELTs ER-N:  
AP INTEGRA (ER-N) P/N S1850501-03, AF INTEGRA (ER-N) P/N S1851501-03  
AF-H INTEGRA (ER-N) P/N S1852501-03, AP-H INTEGRA (ER-N) P/N S1854501-03
- Compatible with all RCP manufactured by Orolia S.A.S.

### Caution

- Shipset “INTEGRA ARINC e-NAV module”, “Bracket Universal for INTEGRA e-NAV ARINC” and INTEGRA ELT must be ordered separately



**INTEGRA e-NAV ARINC module**

# SHIPSET FOR INTEGRA ARINC e-NAV

## Chipset for INTEGRA ARINC e-NAV shall include

- INTEGRA ARINC e-NAV module P/N S1850581-01
- Bracket Universal for INTEGRA e-NAV ARINC for ELT (AP), P/N S1850551-01 or Bracket Universal for INTEGRA e-NAV ARINC for ELT (AF), P/N S1850551-0:
- An ELT INTEGRA (ER-N):  
AP INTEGRA (ER-N) P/N S1850501-03,  
or AF INTEGRA (ER-N) P/N S1851501-03  
or AF-H INTEGRA (ER-N) P/N S1852501-03,  
or AP-H INTEGRA (ER-N) P/N S1854501-03
- An **Optional** Programming Dongle  
Attachable Dongle P/N S1820514-12
- Total weight:  
With Automatic fixed ELTs: 1355 g. max,  
With Automatic portable ELTs: 1555 g. max.
- Overall dimensions:  
With Automatic fixed ELTs: Max 205 mm x 119 mm x 87 mm  
With Automatic portable ELTs: Max 360 mm x 149 mm x 88 mm
- Operating temperatures: -40°C to +55°C

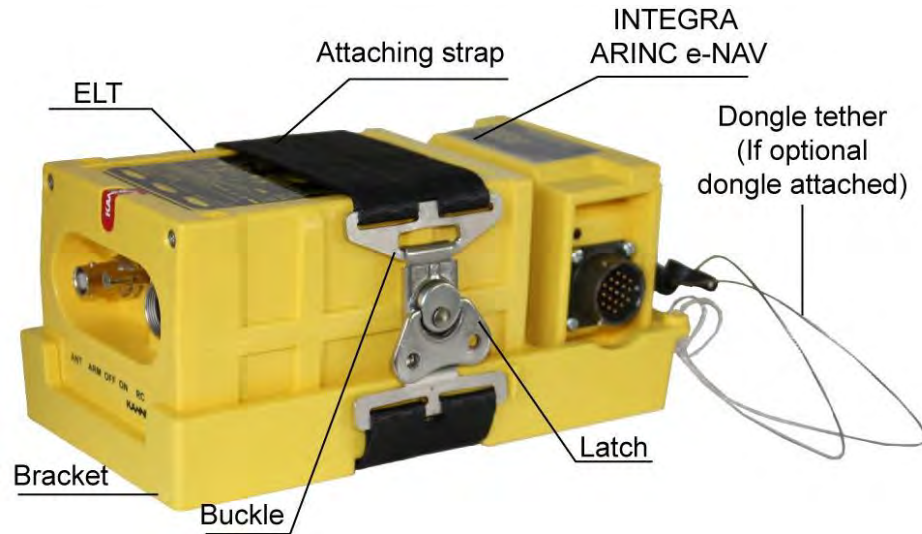

## Bracket Universal for INTEGRA ARINC e-NAV

# MOUNTING BRACKETS



# Mounting brackets (MB)

---

- **For INTEGRA ELTs and KANNAD 406 AF COMPACT**
  - MOUNTING BRACKET, AF-COMPACT P/N S1840502-01
  - COMPACT UNIVERSAL MOUNTING BRACKET P/N S1840502-02
- **For INTEGRA (ER-N) ELTs with ARINC e-NAV interface)**
  - Bracket Universal for INTEGRA ARINC e-NAV for ELT (AP) P/N S1850551-01
  - Bracket Universal for INTEGRA ARINC e-NAV for ELT (AF) P/N S1850551-02

*NOTE: also compatible with other INTEGRA ELTs as bracket TSO-C126b without ARINC e-NAV interface*
- **For automatic 3-Frequency ELTs**
  - MOUNTING BRACKET, 1 STRAP P/N S1820511-01
- **For survival ELTs**
  - MOUNTING BRACKET, AS P/N S1820511-02
  - MOUNTING BRACKET, AS-PLUS P/N S1820511-05
  - CARRY-OFF BAG, AS P/N S1820511-03
  - CARRY-OFF BAG, SHORT P/N S1820511-04

# Mounting Bracket, AF-COMPACT (S1840502-01)

## Main features

- Designed to fix the INTEGRA ELTs (Except P/N S1850501-03, S1851501-03, S1852501-03, S1854501-03), KANNAD 406 AF-COMPACT with a retaining strap for quick removal in an emergency and for easy removal for maintenance or exchange
- Weight: 155g
- Dimensions: 140 x 98 x 16mm
- Designed for OEM and General Aviation
- Strap will be redesigned to comply with TSO C126b for 2014 (P/N subject to be upgraded)



# COMPACT UNIVERSAL Mounting Bracket (S1840502-02)

## Main features

- Designed for retrofit to replace a former 121.5 ELT by a KANNAD 406 AF-COMPACT or an INTEGRA ELT
- Compatible with ACK, AMERIKING, ARTEX, JOLLIET, NARCO, POINTER
- Designed to fix the INTEGRA ELTs (**Except P/N S1850501-03, S1851501-03, S1852501-03, S1854501-03**), KANNAD 406 AF-COMPACT with a retaining strap for quick removal in an emergency and for easy removal for maintenance or exchange
- Weight: 180g
- Dimensions: 175 x 99 x 16mm
- Designed for OEM and General Aviation



# Bracket Universal for INTEGRA ARINC e-NAV for ELT (AP) (S1850551-01)

## Main features

- Specifically designed to keep in place INTEGRA ELTs of AP type and an INTEGRA e-NAV ARINC END Interface including attachment for auxiliary antenna
- Fulfils TSO C126b requirements banning “hook and loop fasteners” as an acceptable means of attachment,
- Weight: Typical 220 g
- Dimensions: Max 204.39 mm x 108.96 mm x 46.7 mm
- Compatible with all AP & AP-H INTEGRA ELTs
- Compatible with INTEGRA ARINC e-NAV, P/N S1850581-01
- Designed for OEM and General Aviation

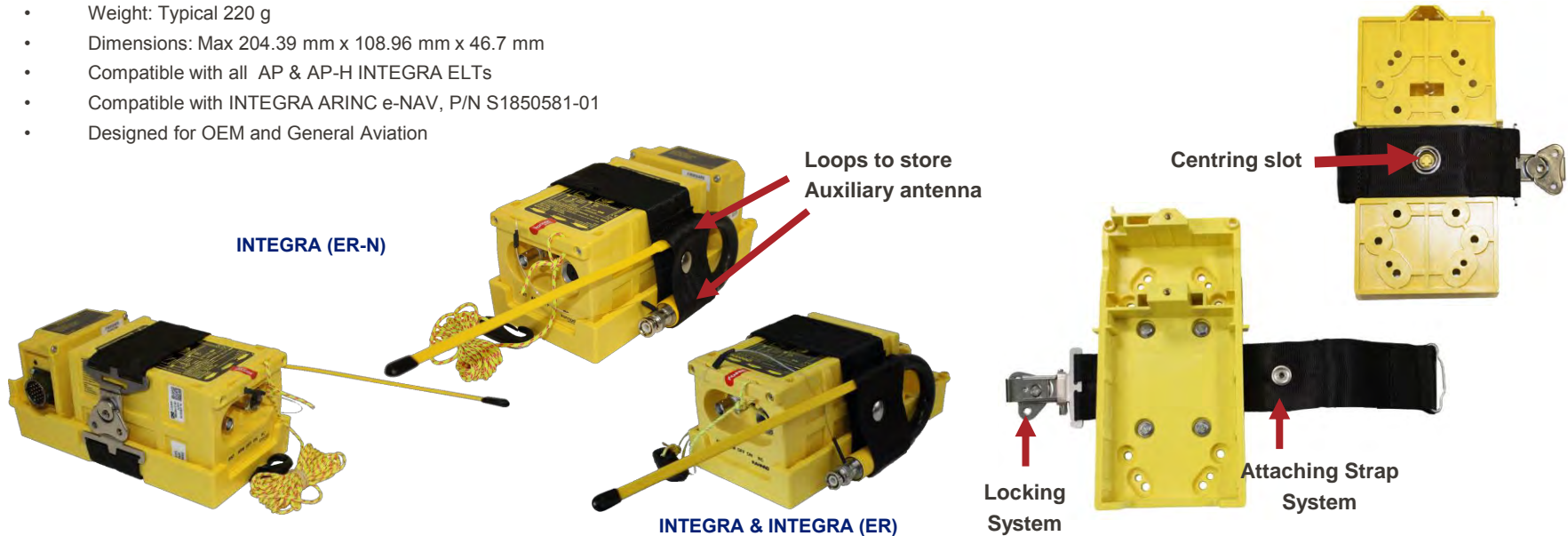

# Bracket Universal for INTEGRA ARINC e-NAV for ELT (AF) (S1850551-02)

## Main features

- Specifically designed to keep in place INTEGRA ELTs of AF type and an INTEGRA e-NAV ARINC END Interface
- Fulfils TSO C126b requirements banning "hook and loop fasteners" as an acceptable means of attachment,
- Weight: Typical 220 g
- Dimensions: Max 204.39 mm x 108.96 mm x 46.7 mm
- Compatible with all AF & AF-H INTEGRA ELTs
- Compatible with INTEGRA ARINC e-NAV, P/N S1850581-01
- Designed for OEM and General Aviation

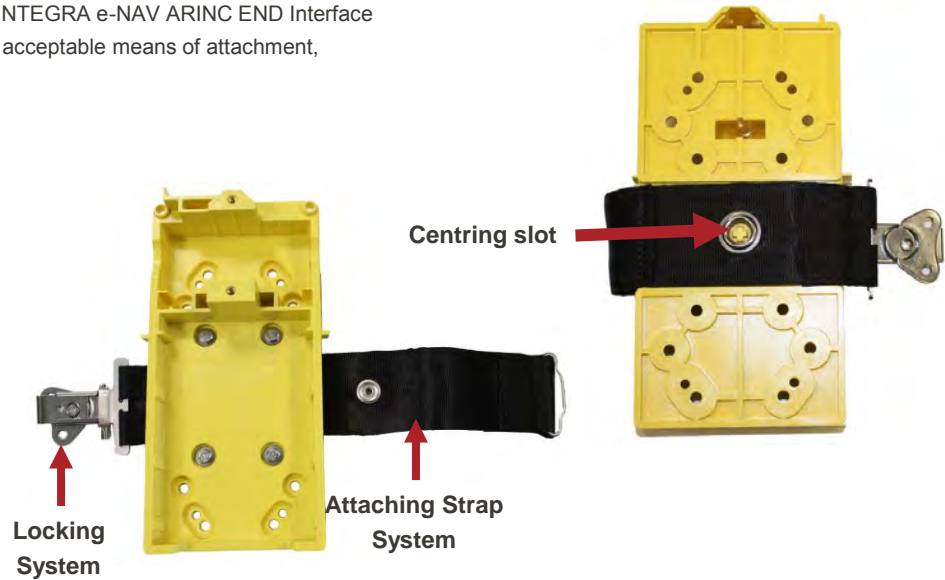
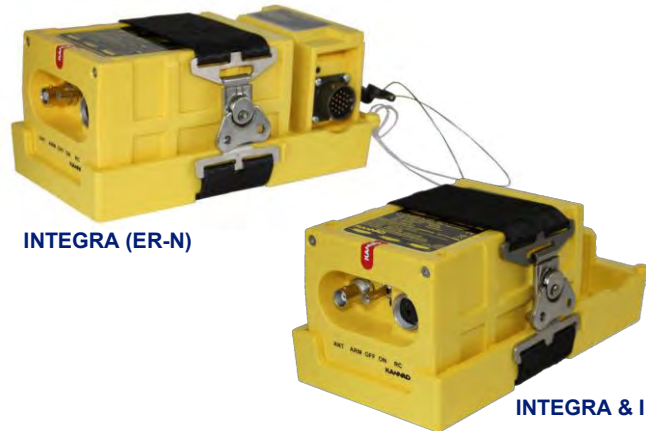

# Mounting Bracket, 1 Strap (P/N S1820511-01)

## Main features

- Designed to fix the ELT with a retaining strap for quick removal in an emergency and for easy removal for maintenance or exchange.
- Designed to hold the auxiliary antenna folded (AP only)
- Able to hold the ELT in place during 500 G shock for 4 ms.
- Made of moulded yellow plastic
- Weight: 175g
- Dimensions: 181 x 94 x 16mm

## Applications

- For KANNAD 406 AP, AP-H, AF, AF-H

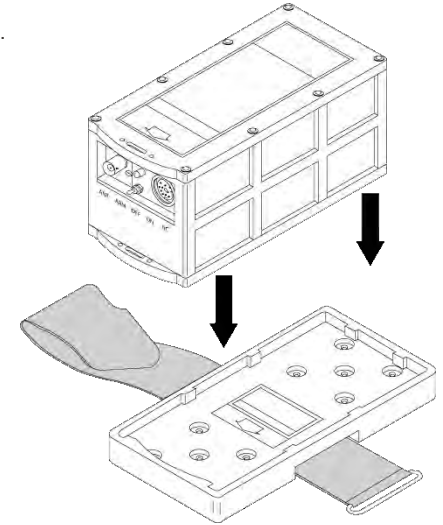
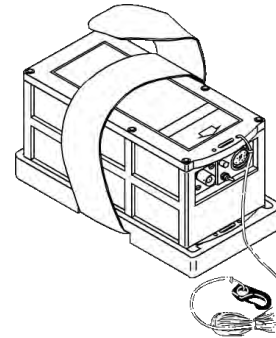
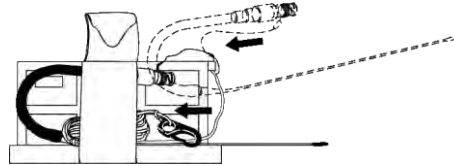

## Caution

- The mounting bracket must be fixed to the primary aircraft load-carrying structure
- It may be necessary to add metal reinforcement if the structure is not rigid enough (if static local deflection is greater than 2.5mm (0.1 inch) when a force of 450 Newtons (100 lbf) is applied to the mount in the most flexible direction)
- The use of the four stainless steel screws with Nylstop nuts provided will ensure that the installation withstands 500G shocks

# Mounting Bracket, AS (P/N S1820511-02)

## Main features

- Designed to:
  - install the ELT aboard the aircraft (retaining fastener)
  - prevent false alarms by means of a locking pin (that must be fitted to ELT)
  - seal the ELT (in order to prevent misuse)
  - store the programming dongle (not accessible when ELT is installed)
- Made of aluminium alloy & yellow foam
- Weight: 205g
- Dimensions: 173 x 80 x 41mm

## Applications

- KANNAD 406 AS and SURVIVAL

## Caution

- This mounting bracket is designed to hold the ELT in place (max 1250g (2.755 lb) when subjected to 9 Gs in any direction as per FAR/JAR 25.561(b)

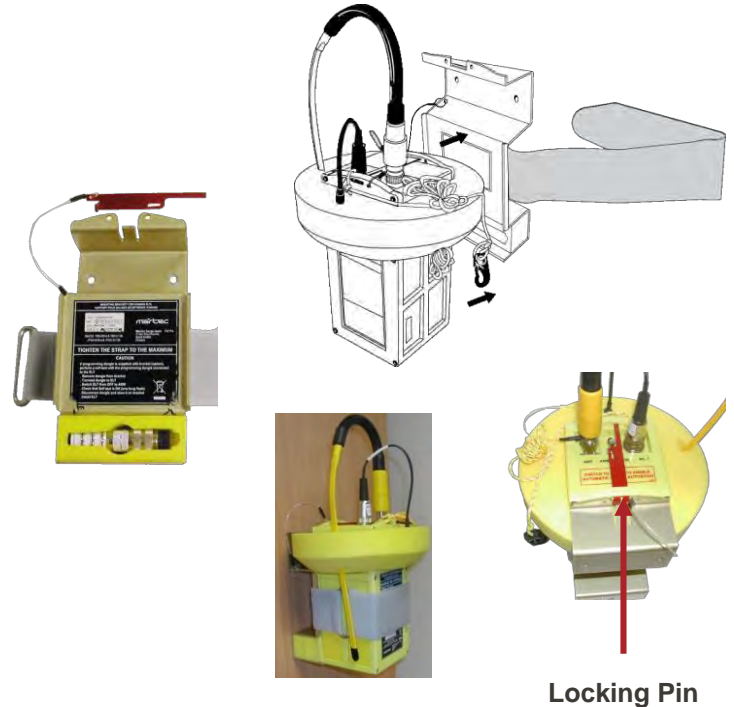

Locking Pin

# Mounting Bracket, AS-PLUS (P/N S1820511-05)

## Main features

- Designed to:
  - install the ELT aboard the aircraft (retaining fastener)
  - prevent false alarms by means of a locking pin (that must be fitted to ELT)
  - seal the ELT (in order to prevent misuse)
- Made of aluminium alloy & yellow foam
- Additional snaps to secure retaining fastener
- Weight: 205g
- Dimensions: 173 x 80 x 41mm

## Applications

- KANNAD 406 AS and SURVIVAL
- Compliant with BOEING requirements

## Caution

- This mounting bracket is designed to hold the ELT in place (max 1250g (2.755 lb) when subjected to 9 Gs in any direction as per FAR/JAR 25.561(b)
- No dongle location

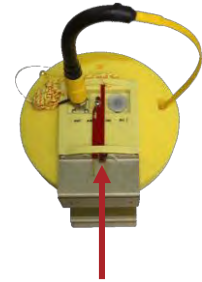
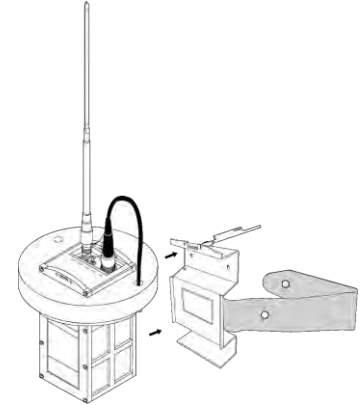

Locking Pin



# Carry-off bag

# Carry-off bag, AS (P/N S1820511-03 or -04)

## Main features

- Designed to stow the KANNAD 406 AS-TNC and KANNAD 406 SURVIVAL ELT with its auxiliary antenna and to protect against shock (Drop tested from a height of 2 meters)
- Three handles for easy access in any position
- Overall dimensions:
- Carry-off bag, AS: 332 x 180 x 180m, P/N S1820511-03
- Carry-off bag short: 290 x 180 x 180mm, P/N S1820511-04
- Weight: 550 g
- The carry-off bag is made of fire resistant materials (the fumes, steam and other inert gas are not toxic)



## Applications

- To stow the KANNAD 406 AS and SURVIVAL
- Selected by AIRBUS, UNITED AIRLINES, UPS...

# Remote Control Panels

# Remote Control Panels Common features

---

- All RCPs enable remote control and remote monitoring of ELTs manufactured by Orolia S.A.S. when ELT switch is in “ARM” position
- Powered by ELT battery
- Remote control with a 3-position remote switch:
  - “ ON ” activates the ELT manually
  - “ ARMED ” is an idle position. Except in the case of an emergency, the switch must remain in this position (on the ground and during flight)
  - “ RESET / TEST ” to stop the ELT transmission after activation or to perform a self test
- Monitoring with a LED (red or amber):
  - 2 Hz pulsating signal during ELT transmission on 121,5 & 243MHz
  - one long flash during ELT transmission on 406MHz (every 50 seconds)
  - one short flash at the beginning of the self-test sequence
  - 3 + N short flashes at the end of the self-test sequence means ELT is faulty (N depends on type of failure)
  - 1 long flash at the end of the self-test sequence means ELT is OK

Note : The toggle switch is locked in positions “ARMED” and “ON”. The “Self-test” position is spring loaded.

# Remote Control Panels (RCP)

---

## Kits

- REMOTE CONTROL PANEL KIT, RC100 P/N S1820513-03
- REMOTE CONTROL PANEL KIT, RC150 P/N S1820513-07
- REMOTE CONTROL PANEL KIT, RC102 P/N S1820513-21

## LRUs

- REMOTE CONTROL PANEL, KIT RC200 P/N S1820513-18
- REMOTE CONTROL PANEL, KIT RC200-NVG P/N S1820513-19
  
- REMOTE CONTROL PANEL, RC300 P/N S1820513-09
- REMOTE CONTROL PANEL, RC300-NVG P/N S1820513-10
- REMOTE CONTROL PANEL RC310 P/N S1820513-26
- REMOTE CONTROL PANEL, RC400 P/N S1820513-05
- REMOTE CONTROL PANEL, RC600-NVG (Y) P/N S1820513-12
- REMOTE CONTROL PANEL, RC600-NVG (W) P/N S1820513-13
- REMOTE CONTROL PANEL, RC800 P/N S1820513-15
- REMOTE CONTROL PANEL, RC810 P/N S1820513-23

## Accessories

- OUTSIDE BUZZER ASSEMBLY P/N S1820515-06

# Remote Control Panel Kits, RC100 / 150

## Main features

- Kit including toggle switch, LED mounting, LED, buzzer, Resistor
- Can be installed directly on the instrument panel or with other remote controls (CVR, FDR...) on a remote control unit.
- The kit can be mounted in the shop and installed aboard the aircraft from the back of the panel.
- Two versions are available:
  - RC100 (P/N S1820513-03) with switch Diam 6,35mm
  - RC150 (P/N S1820513-07) with switch Diam 12mm

## Applications

- Little space available on instrument panel
  - BOMBARDIER DASH8-Q400 (installed with the CVR controls)
  - SUKHOI RRJ100
  - Robinson Helicopters
- Custom Kitting

## Caution

- The wires and the connector are not supplied

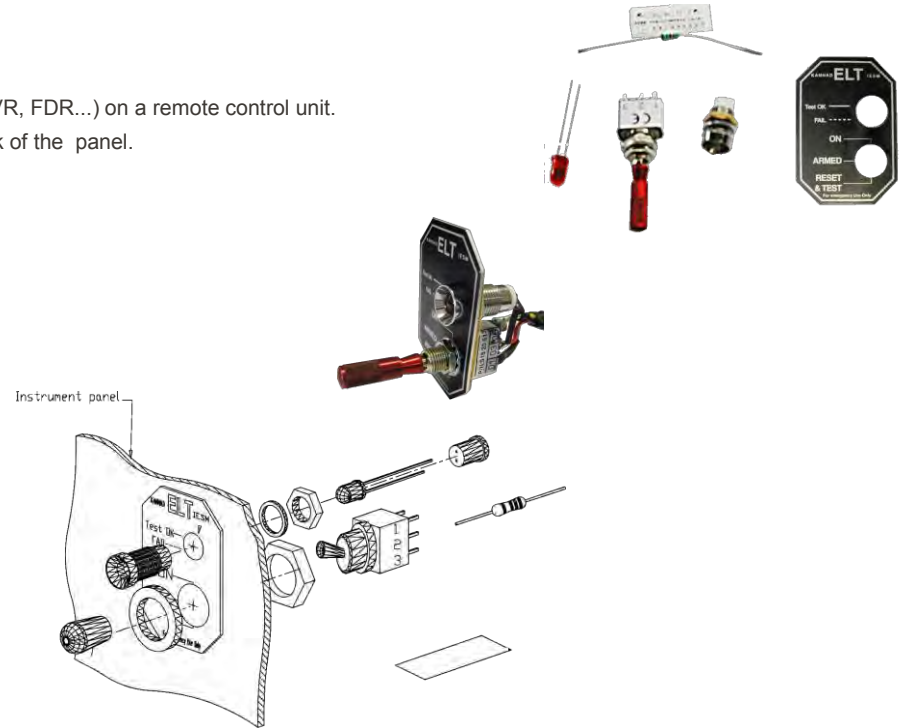

# Remote Control Panel Kit, RC102

## Main features

- 2-Wire remote control panel
- Kit including toggle switch + PCB, LED mounting, a choice of 2 LEDs (standard LED and NVG LED), a choice of 2 front plates. For 121.5 ELT retrofit, the rectangular front plate may replace a former RCP with same dimensions.
- Can be installed directly on the instrument panel or with other remote controls (CVR, FDR...) on a remote control unit.
- The kit can be mounted in the shop and installed aboard the aircraft from the back of the panel

## Applications

- The wires and the connector are not supplied

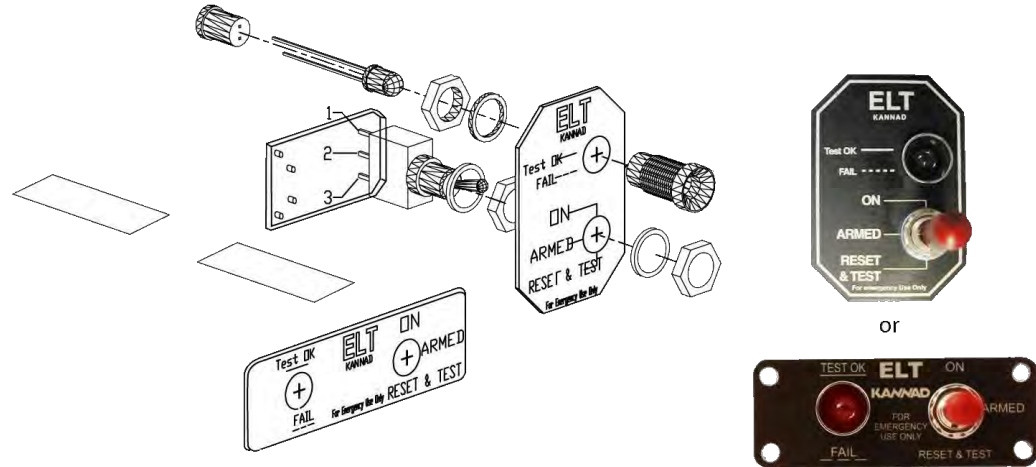

# Remote Control Panel, Kit RC200 (P/N S1820513-18)

## Main features

- Weight: 50g.
- Dimensions : 33 x 50 x 43mm
- 3-position red switch (ON, ARMED, TEST/RESET)
- D-SUB 9 pin connector with threaded locking device (UNC 4-40)
- Output to drive an external buzzer
- Output to control an external horn or annunciator (up to 1A)
- **the Kit includes mating SUB-D9 connector for easier installation**



## Applications

- All aircraft
- Straight replacement for ARTEX RCPs to ensure easy replacement of your old two frequency ELT

## Caution

- Switch is not waterproof. Cannot be installed flat





# Remote Control Panel, Kit RC200-NVG (P/N S1820513-19)

## Main features

- NVG-compatible green A led annunciator
- Weight: 50g
- Dimensions : 33 x 50 x 43mm
- 3-position red switch (ON, ARMED, TEST/RESET)
- D-SUB 9 pin connector with threaded locking device (UNC 4-40)
- Output to drive an external buzzer
- Output to control an external horn or annunciator (up to 1A)
- **the Kit includes mating SUB-D9 connector for easier installation**



## Applications

- The RC200-NVG is a variant of the RC200
- This version is specially intended for military aircraft with NVG-compatible cockpit

## Caution

- Switch is not waterproof. Cannot be installed flat



# Remote Control Panel, RC300 (P/N S1820513-09)

## Main features

- Black front panel with white lettering
- Requires 4 or 5 AWG24 wires to connect to the ELT
- Amber LED operates as the ELT LED
- Internal buzzer warns the pilot of an activation
- Output to drive an external buzzer
- Weight: 120g
- Dimensions : 146 x 63.5 x 38.1mm
- DZUS fasteners

## Applications

- Designed for civil aircraft or helicopter cockpit on retrofit basis

## Caution

- The optional outside buzzer must be ordered separately (P/N S1820515-06)



# Remote Control Panel, RC300-NVG (P/N S1820513-10)

## Main features

- Black front panel with yellow characters compatible with Night Vision Goggles (NVG)
- Requires 4 or 5 AWG 24 wires to connect to the ELT
- Amber LED operates as the ELT LED
- Internal buzzer warns the pilot of an activation
- Output to drive an external buzzer
- Weight: 120g
- Dimensions: 146 x 63.5 x 38.1mm
- DZUS fasteners

## Applications

- The RC300-NVG is a variant of RC300
- This version is specially intended for military aircraft (Super Puma)

## Caution

- The optional outside buzzer must be ordered separately (P/N S1820515-06)



# Remote Control Panel, RC310 NVG (P/N S1820513-26)

## Main features

- Compatible with all Kannad Aviation ELTs
- Black anodized front panel with 5. Illuminated markings in backlight area (black surface, white letters, NVIS green B back lighted)
- Requires 4 AWG24 wires to connect to the ELT
- Blue LED NVIS compatible operates as the ELT LED
- Internal buzzer warns the pilot of an activation
- Weight: 96 g.
- Dimensions: 64 x 22 x 50 mm
- Fixation by 2 screws, washers and anchor nuts with self-locking threads

## Applications

- The RC310 is designed for civil aircraft, commuters or helicopters with NVIS compatible cockpit



# Remote Control Panel, RC400 (P/N S1820513-05)

## Main features

- Black front panel with white lettering
- Requires 4 or 5 AWG24 wires to connect to the ELT
- Amber LED operates as the ELT LED
- Internal buzzer warns the pilot of an activation
- Output to drive an external annunciator or horn (up to 1A @ 28V)
- Weight: 235g
- Front plate dimensions: 146 x 38mm
- Depth (behind front panel): 100mm

## Applications

- Airliner retrofit
- PILATUS PC12

## Caution

- The “outside horn” is not powered by the ELT. It requires 10-30V power supply from the aircraft



# Remote Control Panel, RC600-NVG (Y) (P/N S1820513-12)

## Main features

- Black front panel with yellow fluorescent markings
- Requires 4 or 5 AWG24 wires to connect to the ELT
- NVG-compatible Amber LED operates as the ELT LED
- Internal buzzer warns the pilot of an activation
- Two Outputs to drive an external annunciator and/or horn (up to 1A @ 28V)
- Weight: 235g
- Front plate dimensions: 146 x 38mm
- Depth (behind front panel): 62mm

## Applications

- Non ETSO Equipment
- For military aircraft
- Designed for EUROCOPTER TIGER

## Caution

- The “outside horn” and “outside lamp” signals are not powered by the ELT, but require connection to aircraft power



# Remote Control Panel, RC600-NVG (W) (P/N S1820513-13)

## Main features

- Black front panel with white lettering
- Requires 4 or 5 AWG24 wires to connect to the ELT
- NVG compatible Amber LED operates as the ELT LED
- Internal buzzer warns the pilot of an activation
- Two Outputs to drive an external annunciator and/or horn (up to 1A @ 28V)
- Weight: 235g
- Front plate dimensions: 146 x 38mm
- Depth (behind front panel): 62mm

## Applications

- Non ETSO Equipment
- For military aircraft
- Designed for EUROCOPTER NH90

## Caution

- The “outside horn” and “outside lamp” signals are not powered by the ELT. They requires connection to aircraft power.



# Remote Control Panel, RC800 (P/N S1820513-15)

## Main features

- Grey-Blue front panel with white markings and backlight
- Amber LED operates as the ELT LED
- Chromaticity / Brightness: compliant with ABD0023
- Recessed switch lever
- Internal buzzer warns the pilot of an activation
- Output to drive an external annunciator or horn (up to 1A @ 28V)
- Requires 4 or 5 AWG24 wires to connect to the ELT
- Weight: 225g
- Front plate dimensions: 146 x 38mm
- Depth (behind front panel): 89mm

## Applications

- Airliners
- Compatible with following AIRBUS aircraft:
  - Single aisle: A318, A319, A320, A321, A320neo family
  - Long range: A330, A340
- Interchangeable with RC500-320 RCP

## Caution

- The “outside horn” is not powered by the ELT. It requires 10V to 30V power supply from the aircraft





# Remote Control Panel, RC810 (P/N S1820513-23)

## Main features

- Grey-Blue front panel with white markings and backlight
- Amber LED operates as the ELT LED
- Chromaticity / Brightness: compliant with ABD0023
- Recessed switch lever
- Internal buzzer warns the pilot of an activation
- Output to drive an external annunciator or horn (up to 1A @ 28V)
- Requires 4 or 5 AWG24 wires to connect to the ELT
- Weight: 225g
- Front plate dimensions: 146 x 38mm
- Depth (behind front panel): 89mm

## Applications

- Airliners
- Specially designed for AIRBUS A380
- Compatible with following AIRBUS aircraft:
  - Single aisle: : A318, A319, A320, A321, A320neo family
  - Long range: A380, A350, A330, A340
- Interchangeable with RC810 RCP

## Caution

- The “outside horn” is not powered by the ELT. It requires 10V to 30V power supply from the aircraft



# Buzzer

# Outside Buzzer Assembly (P/N S1820515-06)

## Main features

- Gives an audio indication of emergency location transmitter (ELT) activation through a buzzer that has an oscillator which generates a pulse tone.
- A mounting tray is supplied to install the buzzer on the aircraft. This mounting tray is attached to the aircraft structure either with 3 x M3 screws, washers and nuts or with 3 rivets and washers
- The power is supplied by the ELT battery (no additional power required)
- Weight: 40 g (0.088 lbs)
- Frequency: 3500 Hz  $\pm$  15%
- Pulse rate: approx: 1 Hz
- Sound pressure: 86 dBa at 1 meter (3.28 ft.)

## Applications

- If the ELT buzzer is not audible from outside of the aircraft
- The precise location must be determined so that the buzzer can be heard with the aircraft engine(s) off
- Compatible with all ELTs and Remote Control Panels manufactured by Orolia S.A.S. except RC310-NVG

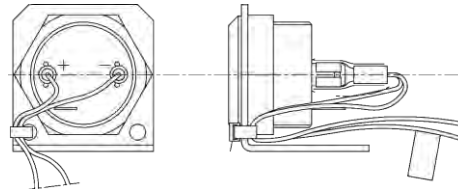

# Antennas

# Antennas (ANT)

---

## Auxiliary

- AUXILIARY ANTENNA, ANT100 (BNC) P/N 0124206
- AUXILIARY ANTENNA, ANT110 (TNC) P/N 0124194

## Whip

Note: suggested for fitting to fixed wing application

- WHIP ANTENNA, RAMI AV100
- WHIP ANTENNA, RAMI AV200 P/N 0146150

## Rod

- ROD ANTENNA, RAMI AV300 P/N 0146151

## Blade

- BLADE ANTENNA, ANT500 P/N 0124222
- BLADE ANTENNA, ANT560 P/N 0145787
- BLADE ANTENNA, ANT650 P/N 0124251

# Auxiliary Antenna, ANT100 (BNC) (P/N 0124206)

## Main features

- Developed by PROCOM
- 1/2 Wave UHF
- 1/4 Wave VHF
- BNC Connector
- Height: 435mm

## Applications

- KANNAD 406 ATP / AP / AS

## Caution

- Old reference: HAF00118
- A KANNAD 406 AF associated with an ANT100 cannot be used as an KANNAD 406 AP even if it may look identical

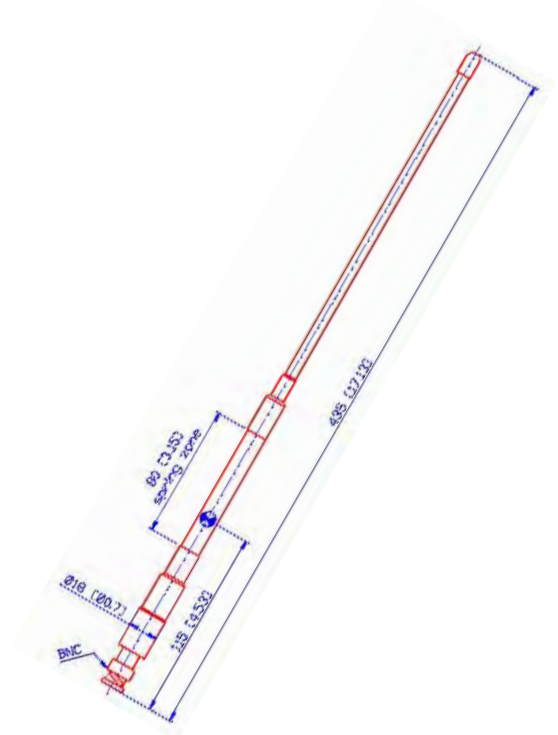

# Auxiliary Antenna, ANT110 (TNC) (P/N 0124194)

## Main features

- Developed by PROCOM
- 1/2 Wave UHF
- 1/4 Wave VHF
- TNC connector
- Height 435 mm

## Applications

- KANNAD 406 AS (TNC) and SURVIVAL

## Caution

- Old reference : HAF00102

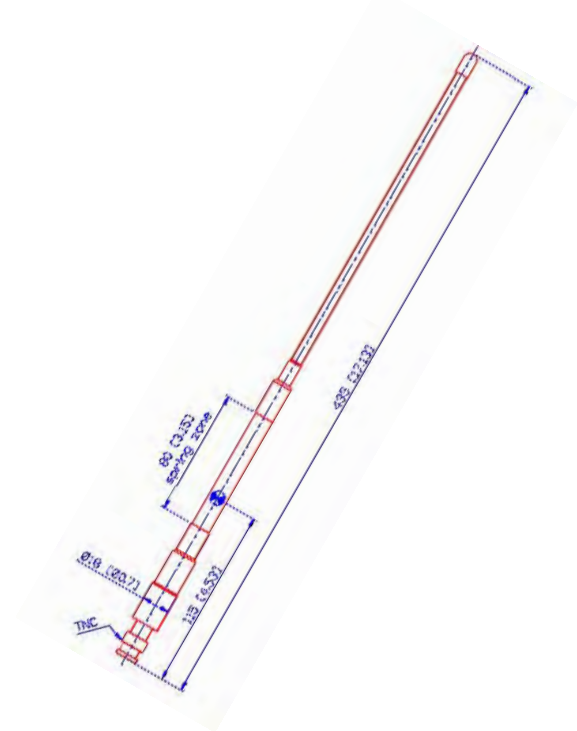

# Whip Antenna, RAMI AV100 P/N 0147444

**Note: suggested for fitting to fixed wing application**

## Main features

- Developed by RAMI
- Whip dual frequency antenna (121.5 / 406 MHz)
- Can easily be installed through a single hole (Ø 13 mm, 0.515 in.) in the aircraft skin
- Female BNC connector
- Impedance 50 ohms
- VSWR:
- 2.0:1 or better@121.5 MHz
- 1.5:1 or better@406 MHz
- Weight: 85g
- Height: 350 mm

## Applications

- Aircraft up to 250kts
- TSO C126a

## Caution

- Delivered with FAA FORM 8130

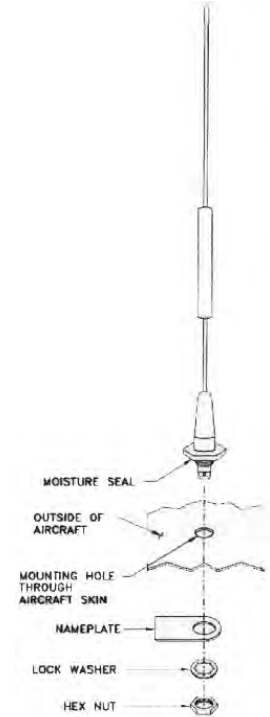



# Whip Antenna, RAMI AV200 P/N 0146150

**Note: suggested for fitting to fixed wing application**

## Main features

- Developed by RAMI
- Whip dual frequency antenna (121.5 / 406 MHz)
- Can easily be installed through a single hole (Ø 13 mm, 0.515 in.) in the aircraft skin
- Female BNC connector
- Impedance 50 ohms
- VSWR:
  - 2.0:1 or better@121.5 MHz
  - 1.5:1 or better@406 MHz
- Weight: 85g
- Height: 609.6mm

## Applications

- Aircraft up to 250kts
- TSO available

## Caution

- Delivered with FAA FORM 8130

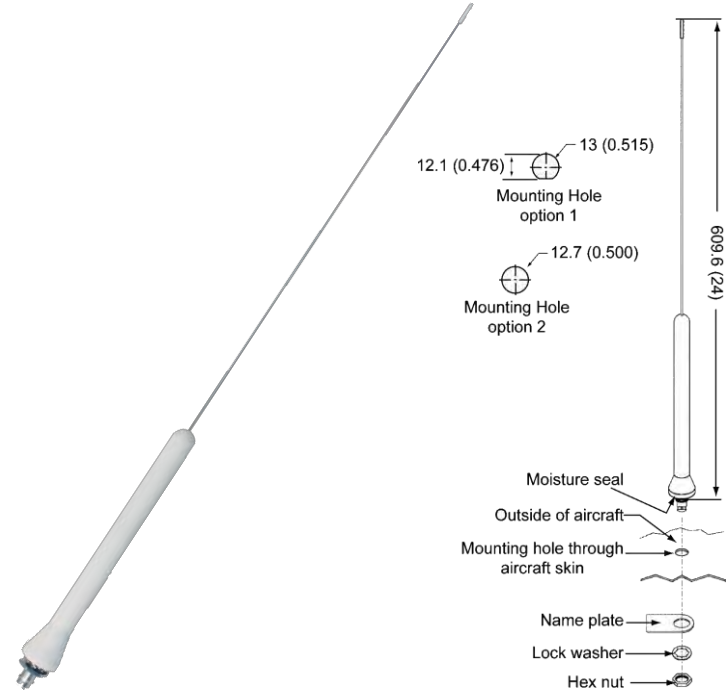

# Rod Antenna, RAMI AV300 P/N 0146151

**Note: suggested for fitting to fixed wing application**

## Main features

- Developed by RAMI
- Small whip for radiation on the COSPAS-SARSAT 3 frequencies (121.5 / 243 / 406MHz)
- Glass fibre
- Metallic base plate with 3 fixing holes
- BNC connector
- VSWR:
- 2.0:1 or better@121.5 MHz
- 2.0:1 or better@243 MHz
- 1.5:1 or better@406 MHz
- Max. Power 10W CW
- Vertical polarisation
- Efficiency > 85%
- Weight: 255g
- Height: 355mm

## Applications

- Aircraft up to 350kts

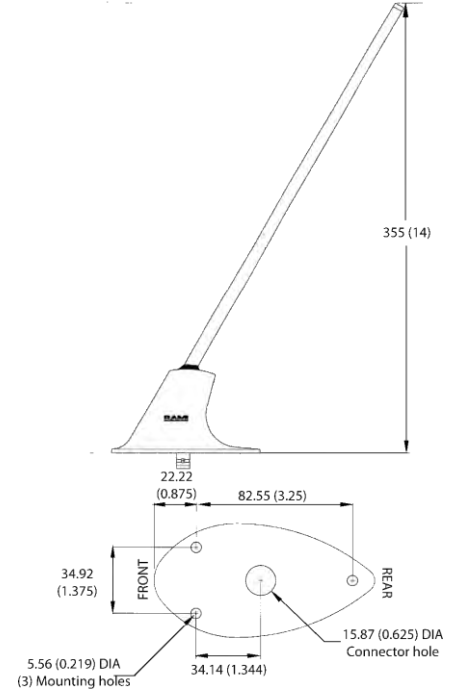

# Blade Antenna, ANT500 (Orolia P/N 0124222, Manufacturer P/N S65-8282-406)

## Main features

- Developed by SENSOR SYSTEMS
- Fully compatible with the range of all ELTs manufactured by Orolia S.A.S (except 406 AF-COMPACT)
- T6 Aluminium + glass fibre
- Skydrol resistant enamel Finish
- BNC connector
- VSWR <2.3
- Max. Power 5W CW
- Vertical polarisation
- Weight: 730g
- Height: 249mm

## Applications

- “high speed” aircraft (jets, airliners)
- TSO available

## Caution

- Manufacturer P/N : S65-8282-406
- Delivered with FAA FORM 8130

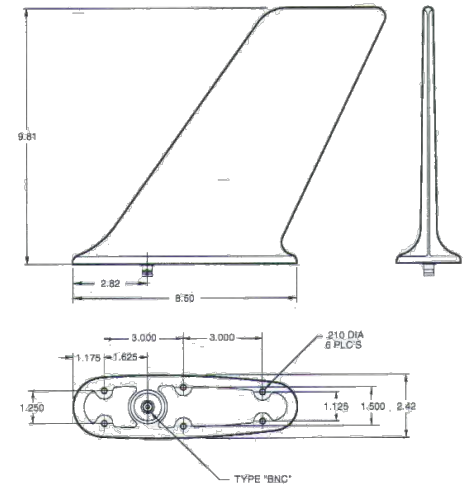

# Blade Antenna, ANT560 (Orolia P/N 0145787, Manufacturer P/N ELT 10-696-1)

## Main features

- Developed by Dayton Granger
- Fully compatible with the range of all ELTs manufactured by Orolia S.A.S (except 406 AF-COMPACT)
- BNC connector
- VSWR
- 2.0:1 or better @121.5 /243MHz
- 1.5:1 or better @406.0 MHz
- Vertical polarisation
- Impedance (RF): 50 Ohms
- Finish: MIL-C-85285 , color white #17925 per FED-STD-595
- Weight: 544g
- Height: 228.6mm

## Applications

- “high speed” aircraft (jets, airliners)
- TSO available

## Caution

- Manufacturer P/N: ELT 10-696-1
- Delivered with FAA FORM 8130

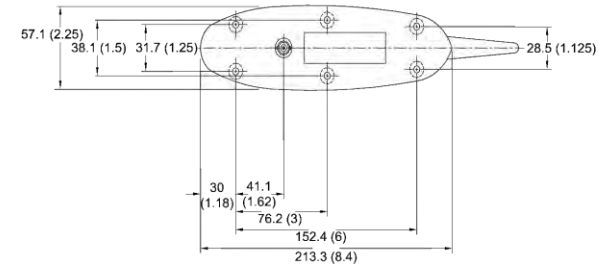
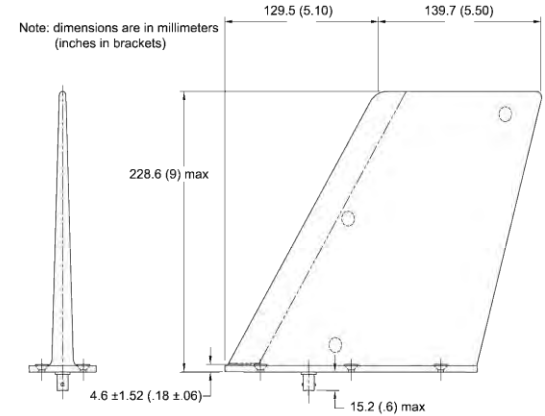

# Blade Antenna, ANT650 (Orolia P/N 0124251, Manufacturer P/N 2624-82)

## Main features

- Developed by RAYAN
- Fully compatible with the range of all ELTs manufactured by Orolia S.A.S (except 406 AF-COMPACT)
- High performance low profile outside antenna designed for Corporate jets and airliners
- Aviation aluminium alloy one piece base plate casting
- Glass fibre laminated radome
- Leading edge coated with erosion treatment
- Filled with close-cell polyurethane foam
- BNC connector
- VSWR <1.5
- Max. Power 100W CW
- Weight: 540g
- Height: 250mm

## Applications

- “high speed” aircraft
- JTSO and TSO
- Installed as standard feature on AIRBUS aircraft

## Caution

- Manufacturer P/N : 2624-82
- Delivered with EASA FORM 1

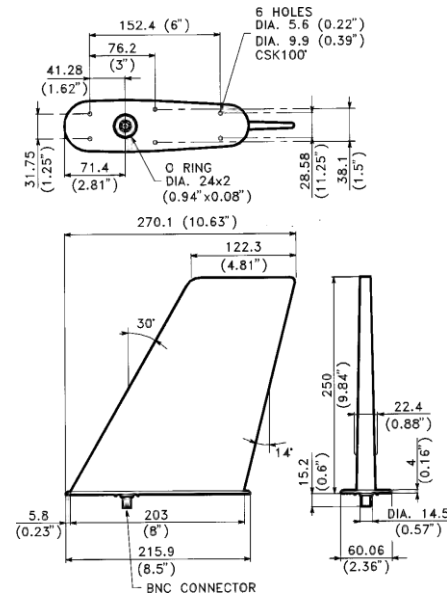

# Connectors and Dongles

# Connectors and “Dongles” (Programming Dongles)

---

## Connector

- DIN12 CONNECTOR P/N S1820514-03

## Dongles

- PROGRAMMING DONGLE P/N S1820514-01
- PROGRAMMING DONGLE, A320 P/N S1820514-04
- PROGRAMMING DONGLE, A330&340 P/N S1820514-05
- PROGRAMMING DONGLE ASSY P/N S1820514-06
- PROGRAMMING DONGLE INTEGRA / LR P/N S1820514-07
- PROGRAMMING DONGLE INTEGRA / SA P/N S1820514-11
- ATTACHABLE PROGRAMMING DONGLE P/N S1820514-12

## For maintenance (shop)

- MAINTENANCE DONGLE P/N S1820514-02

# DIN12 Connector (P/N S1820514-03)

## Main features

- Type DIN (Specification DIN45321)
- 12 contacts
- For ELT-RCP connection (ELT side)

## Applications

- Compatible with all ELTs manufactured by Orolia S.A.S.

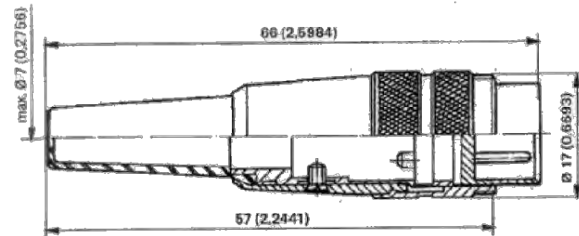



# Programming Dongle (P/N S1820514-01)

## Main features

- DIN 12 connector with serial memory module (SMM) for programming operations
- Contains the aircraft identification data automatically downloaded to the ELT when switched to ARM.
- Avoids the use of specific programming equipment such as PR600 and Computer in case of ELT replacement
- For ELT-RCP connection (ELT side)
- Weight: 20g
- Length: 66mm

## Applications

- Compatible with all ELTs manufactured by Orolia S.A.S except INTEGRA (ER-N)

## Caution

- Programming dongle is required for NAV-ELT interface installation (CS 144)

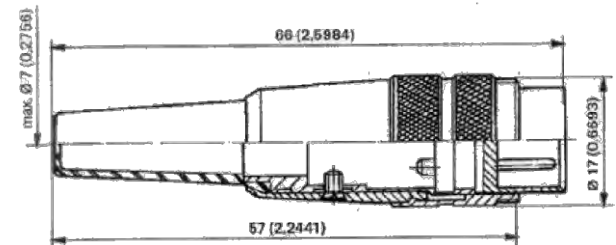

# Programming Dongle, A320 (P/N S1820514-04)

## Main features

- DIN 12 connector with serial memory module (SMM) for programming operations
- Pre-wired variant of the Programming Dongle
- Contains the aircraft identification data (automatically downloaded to the ELT when connected)
- Avoids the use of specific programming equipment such as PR600 + Computer in case of ELT replacement
- Also used as a connector for the remote control panel (RCP)
- Weight 46g
- Length 220mm

## Applications

- Compatible with all 3-Frequency KANNAD 406 ELTs except KANNAD 406 AS and KANNAD 406 SURVIVAL (not compatible with INTEGRA ELTs)
- Compatible with the standard wiring of AIRBUS A320 aircraft



# Programming Dongle, A330 & A340 (P/N S1820514-05)

## Main features

- DIN 12 connector with serial memory module (SMM) for programming operations
- Pre-wired variant of the Programming dongle
- Contains the aircraft identification data (automatically downloaded to the ELT when connected)
- Avoids the use of specific programming equipment such as PR600 + Computer in case of ELT replacement
- Also used as a connector for the remote control panel (RCP)
- Weight: 42g
- Length: 900mm

## Applications

- Compatible with all 3-Frequency KANNAD 406 ELTs except KANNAD 406 AS and KANNAD 406 SURVIVAL (not compatible with INTEGRA ELTs)
- Compatible with the standard wiring of AIRBUS A330 & A340 aircraft



# Programming Dongle, ASSY (P/N S1820514-06)

## Main features

- DIN 12 connector with serial memory module (SMM) for programming operations
- Pre-wired Programming dongle
- Variant of Programming Dongle A320 fitted with a female DIN12 connector on RCP side instead of 19 Pts Jaeger connector
- Contains the aircraft identification data (automatically downloaded to the ELT when connected)
- Avoids the use of specific programming equipment such as PR600 + Computer in case of ELT replacement
- Also used as a connector for the remote control panel (RCP)
- Weight: 45g
- Length: 220mm

## Applications

- Compatible with all ELTs manufactured by Orolia S.A.S except KANNAD 406 AS and KANNAD 406 SURVIVAL  
Not compatible with INTEGRA (ER-N)



# DONGLE INTEGRA L/R (P/N S1820514-07)

## Main features

- DIN 12 connector with serial memory module (SMM) for programming operations
- Pre-wired variant of the Programming dongle
- Contains the aircraft identification data (automatically downloaded to the ELT when connected)
- Avoids the use of specific programming equipment such as PR600 + Computer in case of ELT replacement
- Also used as a connector for the remote control panel (RCP)
- Weight: 42g
- Length: 900mm

## Applications

- Compatible with all INTEGRA ELTs except INTEGRA (ER-N)
- Compatible with the standard wiring of AIRBUS A330 & A340 aircraft



# DONGLE INTEGRA S/A (P/N S1820514-11)

## Main features

- DIN 12 connector with serial memory module (SMM) for programming operations
- Variant of the Programming Dongle A320
- Contains the aircraft identification data (automatically downloaded to the ELT when connected)
- Avoids the use of specific programming equipment such as PR600 + Computer in case of ELT replacement
- Also used as a connector for the remote control panel (RCP)
- Weight 55g,
- Length 250mm

## Applications

- Compatible with all INTEGRA ELTs except INTEGRA (ER-N)
- Compatible with the standard wiring of AIRBUS A318 / A319 / A320 / A321, A320neo Single Aisle aircraft



# Attachable Programming Dongle (P/N S1820514-12)

## Main features

- DIN 12 connector with serial memory module (SMM) for programming operations
- Pre-wired Programming dongle
- Variant of Programming Dongle S1820514-01 fitted with a metallic cable and a clip to fix the dongle to a Mounting Bracket for INTEGRA (ER-N)
- Contains the aircraft identification data (automatically downloaded to the ELT when connected)
- Avoids the use of specific programming equipment such as PR600 + Computer in case of ELT replacement
- Weight: 36g
- Length:  
Connector 66 mm, Cable 310 mm

## Applications

- Optional equipment used for programming the ELT on board
- Compatible with INTEGRA (ER-N) ELTs

## Caution

- **Cannot be used as a connector for the remote control panel**
- **Only for installation on mounting bracket for INTEGRA (ER-N)**



Dongle installed  
on bracket

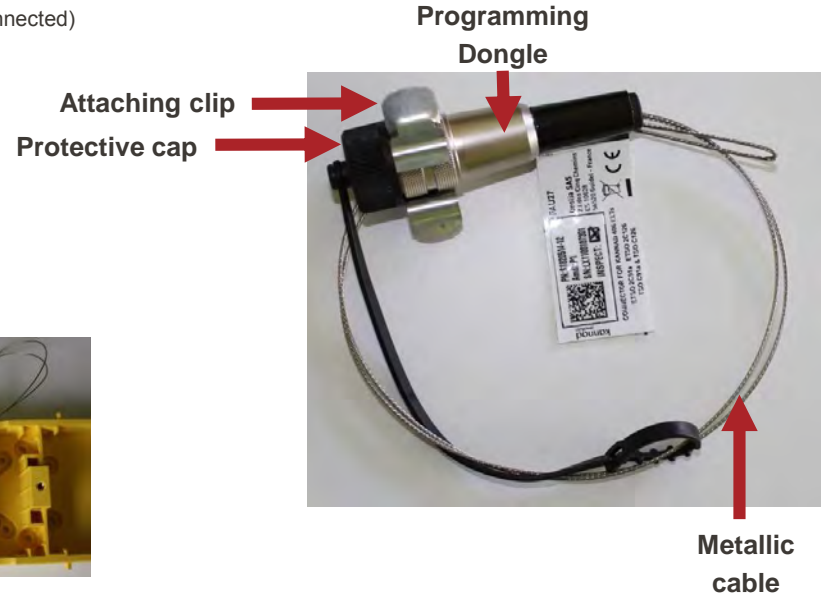
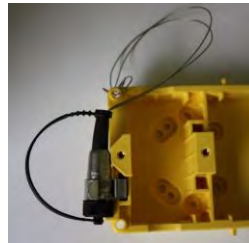

# Maintenance Kit



# Maintenance Kits

---

## Battery Replacement Kits

- KIT BAT200 (P/N S1840510-01)
- KIT BAT300 (P/N S1820516-99)
- KIT BAT350 (P/N S1822505-01)
- KIT BAT500 (P/N S1819516-99)

## Battery replacement is mandatory

- after more than 1 hour of real transmission (cumulated duration);
- before or on the battery expiration date;
- after use in an emergency
- after an inadvertent activation of unknown duration

## Annual Inspection Kit:

- KIT Annual Inspection (P/N S1840510-02)

**USA: FAR 91.207 paragraph (d) requires each emergency locator transmitter must be inspected within 12 calendar months after the last inspection,**

**CANADA: CAR Part VI - Standard 625 Appendix C – 12 (a) requires the ELT shall be inspected at intervals not exceeding 12 months, in accordance with Standard 571 of the CARs.**

# KIT BAT200 (P/N S1840510-01)

**KIT BAT200 shall be used to replace batteries of**

- ALL 406 AF-COMPACT ELTs P/N S1840501-01 and P/N S1840501-02
- All INTEGRA ELTs P/N S185X501-XX



# KIT BAT300 (P/N S1820516-99)

**KIT BAT300 shall be used to replace batteries of**

- ALL 3-Frequency KANNAD ELTs except:
  - KANNAD 406 ATP P/N S1819501-02
  - KANNAD 406 AF-H (HT) P/N S1822504-01



O-RING, P/N 0124115



WEDGE, FOAM, SMALL, P/N 0132014

devices used to make a test mock-up  
for current measurement of battery



WEDGE, FOAM, LARGE, P/N 0132015



LABEL, IDENTIFICATION, P/N 0122993



CAPSULE, DESICCANT, P/N 0123831

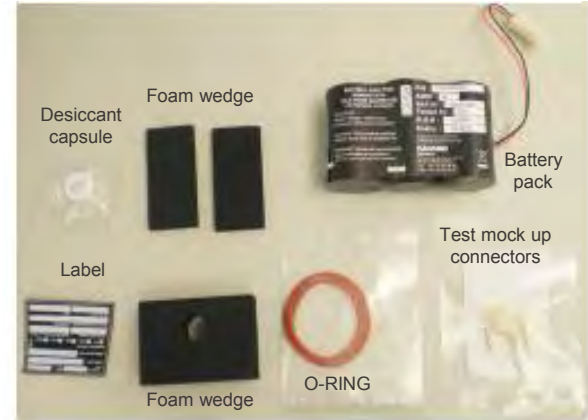

BAT300, P/N S1820506-01  
Always supplied with Battery Kit  
Not procurable out of Battery Kit

# KIT BAT350 (P/N S1822505-01)

**KIT BAT350 shall be used to replace batteries of**

- KANNAD 406 AF-H (HT) P/N S1822504-01



O-RING, P/N 0124115



WEDGE, FOAM, SMALL, P/N 0132014

devices used to make a test mock-up  
for current measurement of battery



WEDGE, FOAM, LARGE, P/N 0132015



LABEL IDENTIFICATION, P/N 0122993



CAPSULE, DESICCANT, P/N 0123831

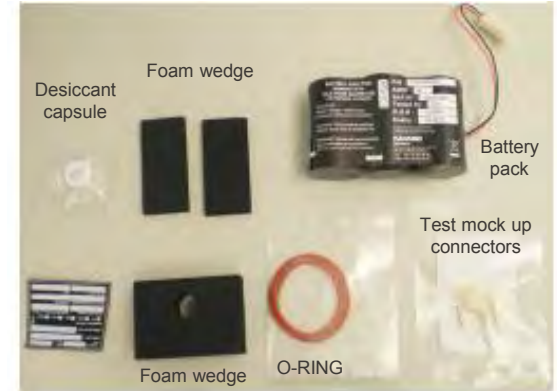

Desiccant capsule

Foam wedge

Battery pack

Test mock up connectors

Foam wedge

O-RING



BAT350, P/N 0144033  
Always supplied with Battery Kit  
Not procurable out of Battery Kit

# KIT Annual Inspection (P/N S1840510-02)

KIT Annual Inspection shall be used to carried out the annual inspections required by FAR 91.207 paragraph (d) and CAR Part VI - Standard 625 Appendix C – 12 (a) for:

- ALL 406 AF-COMPACT ELTs P/N S1840501-01 and P/N S1840501-02
- All INTEGRA ELTs P/N S185X501-XX

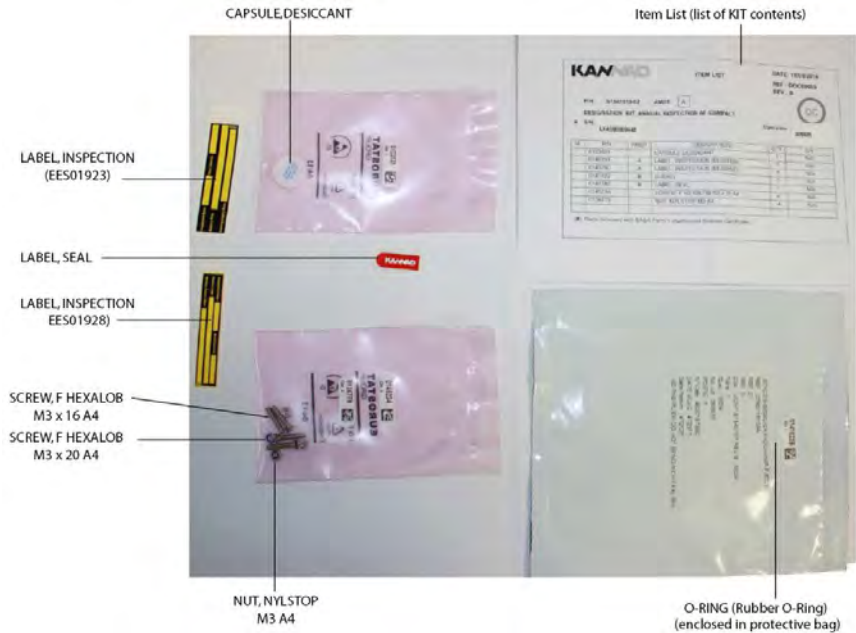

# Ground Support Equipment (GSE)

---

## Programming Equipment (Special GSE):

- PR600 (P/N 1201570)

## Beacon Testers:

- BT100AVTriple (P/N 0140958)

## Dongle (Special GSE):

- Maintenance Dongle (P/N S1820514-02)

# Programming Kit, PR600 (P/N 1201570)

## Main features

- Programming tool and cables
- Works with any PC computer with USB Ports
- WINDOWS 2000 / XP compatible software
- Compatible with the 4 protocols defined by ICAO:
- Tail Number
- Aircraft Operator Designator
- Serial Number
- 24 bit Address ICAO

## Applications

- Compatible with all ELTs manufactured by Orolia S.A.S.
- Compatible with all Programming Dongles manufactured by Orolia S.A.S.
- Replaces the former PR550 Programming equipment
- P/N 1201570 : PR600 programming kit with Windows software includes:
  1. PR600 Programming interface module
  2. USB cable
  3. Instructions for Programming
  4. Suit case storage and transportation

## Caution

- Only trained personnel should use the programming equipment

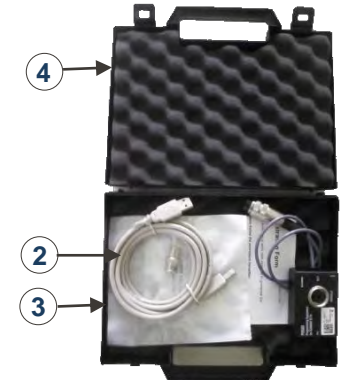

# Programming, Test and Maintenance



# Programming the 406 MHz ELT with the PR600

- **Hardware**
  - ➔ USB port to program ELT and DONGLE
- **Software**
  - ➔ Kannad e-Prog
- **Power supply**
  - ➔ Self-powered by the USB port.
- **Compatibility list**
  - ➔ All Kannad ELTs

```

00  MESSAGE CODES
01  MESSAGE (MAY/IDENT/LOCAL / OTHER)
02  MESSAGE (MAY/IDENT/LOCAL / OTHER)
03  MESSAGE (MAY/IDENT/LOCAL / OTHER)
04  MESSAGE (MAY/IDENT/LOCAL / OTHER)
05  MESSAGE (MAY/IDENT/LOCAL / OTHER)
06  MESSAGE (MAY/IDENT/LOCAL / OTHER)
07  MESSAGE (MAY/IDENT/LOCAL / OTHER)
08  MESSAGE (MAY/IDENT/LOCAL / OTHER)
09  MESSAGE (MAY/IDENT/LOCAL / OTHER)
10  MESSAGE (MAY/IDENT/LOCAL / OTHER)
11  MESSAGE (MAY/IDENT/LOCAL / OTHER)
12  MESSAGE (MAY/IDENT/LOCAL / OTHER)
13  MESSAGE (MAY/IDENT/LOCAL / OTHER)
14  MESSAGE (MAY/IDENT/LOCAL / OTHER)
15  MESSAGE (MAY/IDENT/LOCAL / OTHER)
16  MESSAGE (MAY/IDENT/LOCAL / OTHER)
17  MESSAGE (MAY/IDENT/LOCAL / OTHER)
18  MESSAGE (MAY/IDENT/LOCAL / OTHER)
19  MESSAGE (MAY/IDENT/LOCAL / OTHER)
20  MESSAGE (MAY/IDENT/LOCAL / OTHER)
21  MESSAGE (MAY/IDENT/LOCAL / OTHER)
22  MESSAGE (MAY/IDENT/LOCAL / OTHER)
23  MESSAGE (MAY/IDENT/LOCAL / OTHER)
24  MESSAGE (MAY/IDENT/LOCAL / OTHER)
25  MESSAGE (MAY/IDENT/LOCAL / OTHER)
26  MESSAGE (MAY/IDENT/LOCAL / OTHER)
27  MESSAGE (MAY/IDENT/LOCAL / OTHER)
28  MESSAGE (MAY/IDENT/LOCAL / OTHER)
29  MESSAGE (MAY/IDENT/LOCAL / OTHER)
30  MESSAGE (MAY/IDENT/LOCAL / OTHER)
31  MESSAGE (MAY/IDENT/LOCAL / OTHER)
32  MESSAGE (MAY/IDENT/LOCAL / OTHER)
33  MESSAGE (MAY/IDENT/LOCAL / OTHER)
34  MESSAGE (MAY/IDENT/LOCAL / OTHER)
35  MESSAGE (MAY/IDENT/LOCAL / OTHER)
36  MESSAGE (MAY/IDENT/LOCAL / OTHER)
37  MESSAGE (MAY/IDENT/LOCAL / OTHER)
38  MESSAGE (MAY/IDENT/LOCAL / OTHER)
39  MESSAGE (MAY/IDENT/LOCAL / OTHER)
40  MESSAGE (MAY/IDENT/LOCAL / OTHER)
41  MESSAGE (MAY/IDENT/LOCAL / OTHER)
42  MESSAGE (MAY/IDENT/LOCAL / OTHER)
43  MESSAGE (MAY/IDENT/LOCAL / OTHER)
44  MESSAGE (MAY/IDENT/LOCAL / OTHER)
45  MESSAGE (MAY/IDENT/LOCAL / OTHER)
46  MESSAGE (MAY/IDENT/LOCAL / OTHER)
47  MESSAGE (MAY/IDENT/LOCAL / OTHER)
48  MESSAGE (MAY/IDENT/LOCAL / OTHER)
49  MESSAGE (MAY/IDENT/LOCAL / OTHER)
50  MESSAGE (MAY/IDENT/LOCAL / OTHER)
51  MESSAGE (MAY/IDENT/LOCAL / OTHER)
52  MESSAGE (MAY/IDENT/LOCAL / OTHER)
53  MESSAGE (MAY/IDENT/LOCAL / OTHER)
54  MESSAGE (MAY/IDENT/LOCAL / OTHER)
55  MESSAGE (MAY/IDENT/LOCAL / OTHER)
56  MESSAGE (MAY/IDENT/LOCAL / OTHER)
57  MESSAGE (MAY/IDENT/LOCAL / OTHER)
58  MESSAGE (MAY/IDENT/LOCAL / OTHER)
59  MESSAGE (MAY/IDENT/LOCAL / OTHER)
60  MESSAGE (MAY/IDENT/LOCAL / OTHER)
61  MESSAGE (MAY/IDENT/LOCAL / OTHER)
62  MESSAGE (MAY/IDENT/LOCAL / OTHER)
63  MESSAGE (MAY/IDENT/LOCAL / OTHER)
64  MESSAGE (MAY/IDENT/LOCAL / OTHER)
65  MESSAGE (MAY/IDENT/LOCAL / OTHER)
66  MESSAGE (MAY/IDENT/LOCAL / OTHER)
67  MESSAGE (MAY/IDENT/LOCAL / OTHER)
68  MESSAGE (MAY/IDENT/LOCAL / OTHER)
69  MESSAGE (MAY/IDENT/LOCAL / OTHER)
70  MESSAGE (MAY/IDENT/LOCAL / OTHER)
71  MESSAGE (MAY/IDENT/LOCAL / OTHER)
72  MESSAGE (MAY/IDENT/LOCAL / OTHER)
73  MESSAGE (MAY/IDENT/LOCAL / OTHER)
74  MESSAGE (MAY/IDENT/LOCAL / OTHER)
75  MESSAGE (MAY/IDENT/LOCAL / OTHER)
76  MESSAGE (MAY/IDENT/LOCAL / OTHER)
77  MESSAGE (MAY/IDENT/LOCAL / OTHER)
78  MESSAGE (MAY/IDENT/LOCAL / OTHER)
79  MESSAGE (MAY/IDENT/LOCAL / OTHER)
80  MESSAGE (MAY/IDENT/LOCAL / OTHER)
81  MESSAGE (MAY/IDENT/LOCAL / OTHER)
82  MESSAGE (MAY/IDENT/LOCAL / OTHER)
83  MESSAGE (MAY/IDENT/LOCAL / OTHER)
84  MESSAGE (MAY/IDENT/LOCAL / OTHER)
85  MESSAGE (MAY/IDENT/LOCAL / OTHER)
86  MESSAGE (MAY/IDENT/LOCAL / OTHER)
87  MESSAGE (MAY/IDENT/LOCAL / OTHER)
88  MESSAGE (MAY/IDENT/LOCAL / OTHER)
89  MESSAGE (MAY/IDENT/LOCAL / OTHER)
90  MESSAGE (MAY/IDENT/LOCAL / OTHER)
91  MESSAGE (MAY/IDENT/LOCAL / OTHER)
92  MESSAGE (MAY/IDENT/LOCAL / OTHER)
93  MESSAGE (MAY/IDENT/LOCAL / OTHER)
94  MESSAGE (MAY/IDENT/LOCAL / OTHER)
95  MESSAGE (MAY/IDENT/LOCAL / OTHER)
96  MESSAGE (MAY/IDENT/LOCAL / OTHER)
97  MESSAGE (MAY/IDENT/LOCAL / OTHER)
98  MESSAGE (MAY/IDENT/LOCAL / OTHER)
99  MESSAGE (MAY/IDENT/LOCAL / OTHER)
100 MESSAGE (MAY/IDENT/LOCAL / OTHER)
  
```



Worldwide Programming service through our Distribution and Service Network

# Test Equipment, BT100AVTriple (P/N 0140956)

- Compatible with all COSPAS-SARSAT ELTs
- To decode the signal transmitted by the ELT (real transmission)
- Used for ELT testing (in the shop) and for installation validation
- Manufactured by WS Technology



# Maintenance Dongle, (P/N S1820514-02)

## Main features

- DIN 12 connector with SMM
- “REMOVE BEFORE FLIGHT” Red streamer
- Contains a specific code to “deprogram” the ELT it is connected to. ELT self-test result will be 3+4 flashes and a transmission will not alert Search and Rescue (special code recognized by COSPAS-SARSAT as “ELT not on board”)

## Applications

- Used for ELT removal and maintenance operation

## Caution

- ELT should be unprogrammed before installation on board an aircraft equipped with a programming dongle. If not, deprogram with maintenance dongle

